

AK Folding Stock Directions

Make sure the rifle is unloaded!

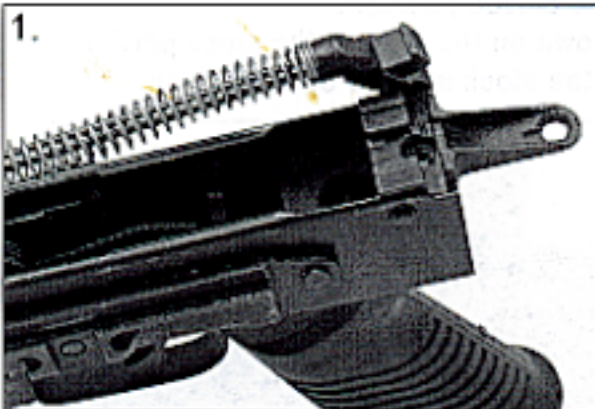

1. Begin with the receiver cover removed, and make sure the rear trunion is clean. Remove the recoil assembly. Once removed, you will now have access to both tang screw openings.

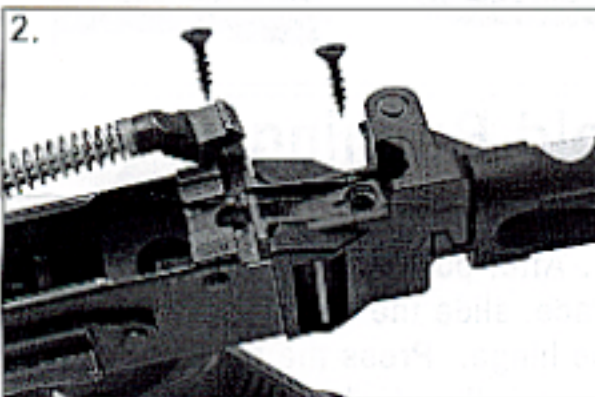

2. Insert the hinged portion of the folding stock into the rear of the stamped receiver (if receiver is milled, this unit will not work). Wearing eye protection and using the supplied 3/32" drill bit, start two pilot holes approximately 3/4" deep into the stock through the screw holes on the receiver. Insert the screws into each of these holes.



3. Once both screws are in place replace the recoil assembly and the receiver cover. Installation is complete.

Sling Attachment

The vertical pin on the left side of the stock is designed to accept slings up to 1 1/4" in width.

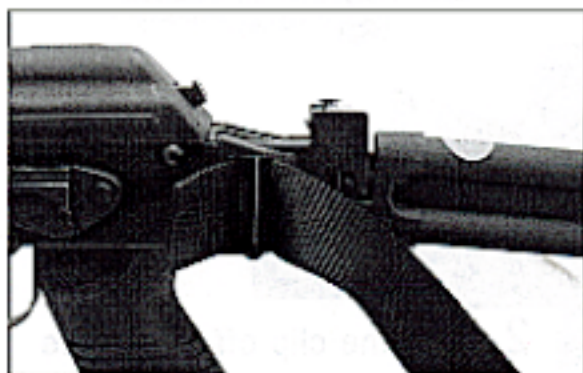

Tech Tips

** Ensure the stock is flush against the receiver when drilling holes.

** Use liquid soap on screws to ease installation.

** Designed to fit 1.05mm gauge thickness receivers. Larger gauge receivers may require trimming.

See reverse for operation and compliance details.



AK Folding Stock Operation

To fold the stock from the open position, you must first disengage the stock portion from the hinge block. This can be accomplished by pressing down on the front of the stock portion (near the hinge). While holding down, you may pivot the stock into the closed position.

To fold the stock back into the open position, again push down on the front of the stock portion (near the hinge block). While holding down, you may pivot the stock into the open position.

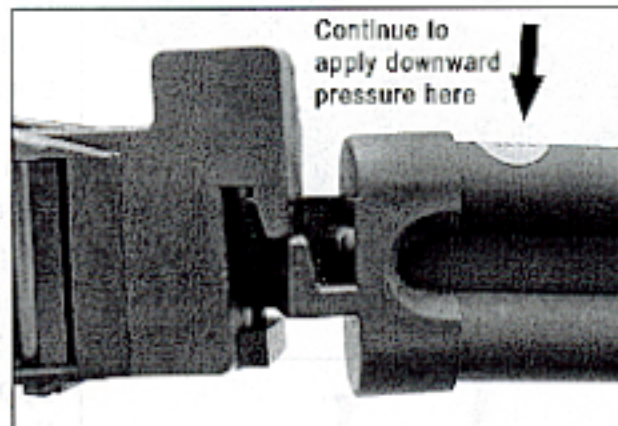
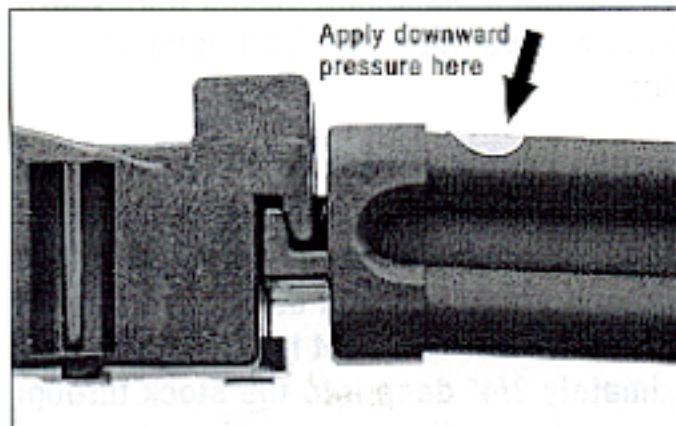

Installing the No-Fold Bushing

Make sure the rifle is unloaded!

1. Remove the retaining clip from the top of the stock hinge pin. Be gentle, you will use it again later.

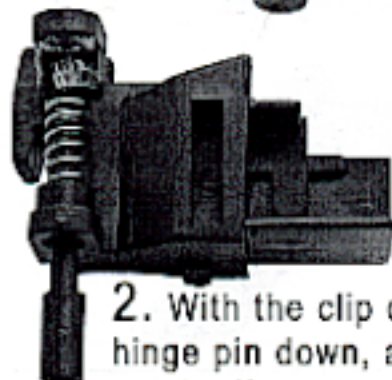
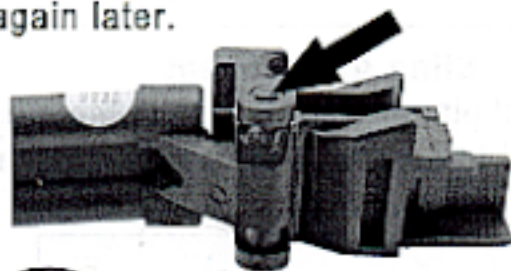

2. With the clip off, press the hinge pin down, and slide the stock off the pin. Now place the bushing on the pin (above the lower hinge).

3. After putting the bushing in place, slide the stock back into the hinge. Press the pin back up through the stock.

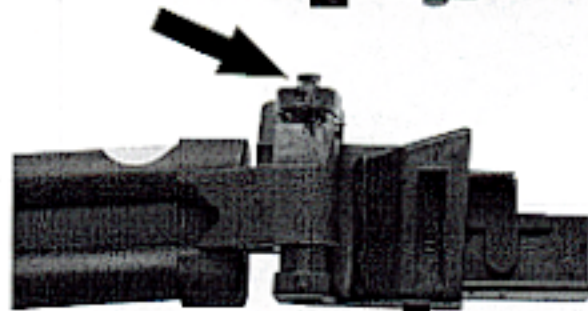
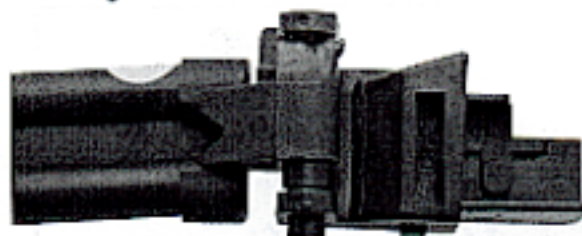

4. Place the retaining clip back into position at the top of the hinge pin. You will notice the stock will not depress now.