

OPERATION MANUAL



OF
Semi - Automatic Rifle
CAL. 7.62 × 39 mm
Type ARM

Manufactured By

MAADI Co. For Engineering. Industries

MAADI - CAIRO

EGYPT



**OPERATION MANUAL
OF
Semi - Automatic Rifle
CAL. 7.62 × 39 mm
Type ARM**

**Manufactured By
MAADI Co. For Engineering. Industries
MAADI - CAIRO
EGYPT**

INTRODUCTION

The semi – automatic rifle A RM 7.62x39 mm. is a unique adoption of the automatic rifle A KM 7.62x39 mm. made by Maadi Company For Engineering Industries, in Egypt.

The ARM rifle is well made, reliable and has several interesting features such as a hard chrome-lined barrel and a hard chrome plated piston, double-roped springs and complete take down without tools.

The ARM fires the M 1943 7.62x39 mm. intermediate cartridges.

Best firing results are obtained at ranges up to 440 yard .

Well trained riflemen can fire aimed semi automatic fire at ranges of up to 650 yard. The bullet retains lethal effect at ranges of up to 1650 yard.

The ARM is a gas-operated weapon, in which the gas is channelled through a special port in the stationary barrel and reacts on a piston. The bore is sealed by rotation of the bolt and engagement of the bolt locking lugs on the receiver. The rifle is fed from a curved box magazine with a capacity of 5 rounds. The firing mechanism is of the hammer type and is actuated by means of spring.

The use of reloaded, remanufactured, handloaded or other non-standard ammunition may result in damage to the rifle .

The manufacturer and importer cannot accept responsibility for malfunctions resulting from the use of non-standard defective ammunition.

TABLE OF CONTENTS

CHAPTER 1- CHARACTERISTICS

CHAPTER 2- FUNCTIONING

- I- Position of parts before loading.
- II- Function of parts during loading.
- III- Function of parts during firing.
- IV- Function of parts during unloading.

CHAPTER 3- DISASSEMBLY AND ASSEMBLY

- I-General instructions.
- II- Field stripping.
- III- Assembly after stripping.
- IV- Detail stripping.
- V- Assembly after detail stripping.
- VI- Disassembly of the magazine.
- VII- Assembly of the magazine.
- VIII- Disassembly and assembly of the rifle in repair shop.

CHAPTER 4- CAUSES OF FAILURE OF THE RIFLE.

- I- General procedure for preventing and elimination of stoppages.
- II- Characteristic malfunctions and methods for clearing them.

CHAPTER 5- CLEANING AND LUBRICATION OF THE RIFLE IN USE.

- I- General
- II- Procedure for cleaning and lubrication.
- III- Cleaning and lubricating rifles in preparation for extended storage.

CHAPTER I

CHARACTERISTICS

DATA

Cartridge	7.62 x 39 mm
Method of operation	Gas
Method of locking	Rotating bolt
Method of feed	5 round detachable box magazine
Method of fire	Single
Weights:	
Rifle without magazine	6.8 lb
Magazine empty	0.4 lb
magazine loaded (5 rounds)	0.6 lb
Trigger Pull	6 lb
Rifle	35 in
Barrel	17 in

MECHANICAL FEATURES

Barrel	
Regulator	NA
Rifling	4 Grooves R.H. 1 turn in 9 1/4 in
Sights :	
Foresight	Pillar
Rearsight	U notch.
Graduation	100 - 1000 meters
Sight radius	367 mm.

FIRING CHARACTERISTICS

Muzzle velocity	2256 ft / sec
Muzzle energy	1480 ft lb
Recoil energy	4.6 ft lb

Chapter 2

FUNCTIONING

I. POSITION OF PARTS BEFORE LOADING:

The rifle is set on safety.

An empty magazine (8) (Fig. 3) is in place in the rifle.

The magazine catch. (9) holds the magazine in the receiver. The bolt (2) and the bolt carrier (4) are held in forward position by the return spring (5) which also holds the gas piston (6) in the gas cylinder (7). The return spring is in its position of least compression.

The bolt is rotated to the right, with its locking lugs engaging the receiver locking lugs. The gripping flange of the extractor is pressed against the centre of the bolt head by the extractor spring. The ejector head is located in the wide rear portion of the groove in the bolt.

The selector is in the extreme top position, obstructing the passage of the cocking handle. The selector lever (21) (Fig. 4) is

rotated forward. This places the selector lever lug directly over the rear end of the disconnecter and the trigger end lugs, preventing both the disconnecter and the trigger from rotation.

The hammer and trigger spring holds the trigger in forward position, with the sear raised.

II. FUNCTIONING OF PARTS DURING LOADING:

The rifle is loaded as follows:

1. Insert a loaded magazine into the receiver.
2. Set the selector to fire position.
3. Pull the cocking handle as far as possible to the rear and release it.

As the magazine is inserted, the magazine stop rotates the magazine catch

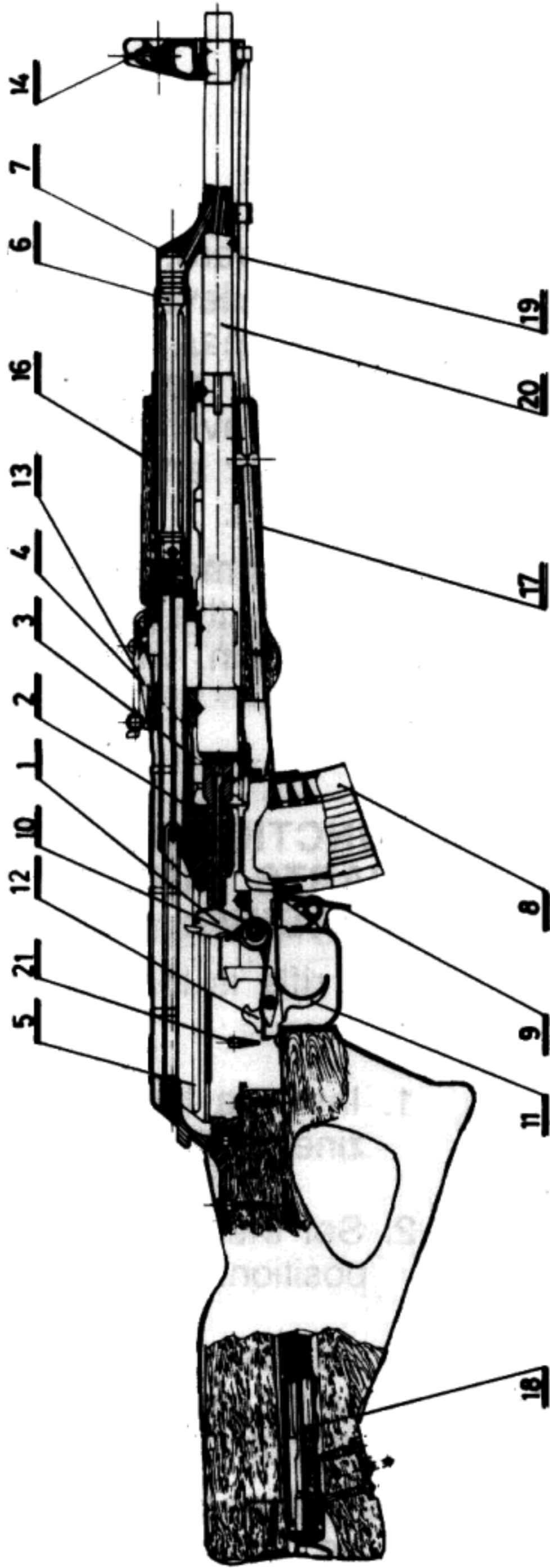
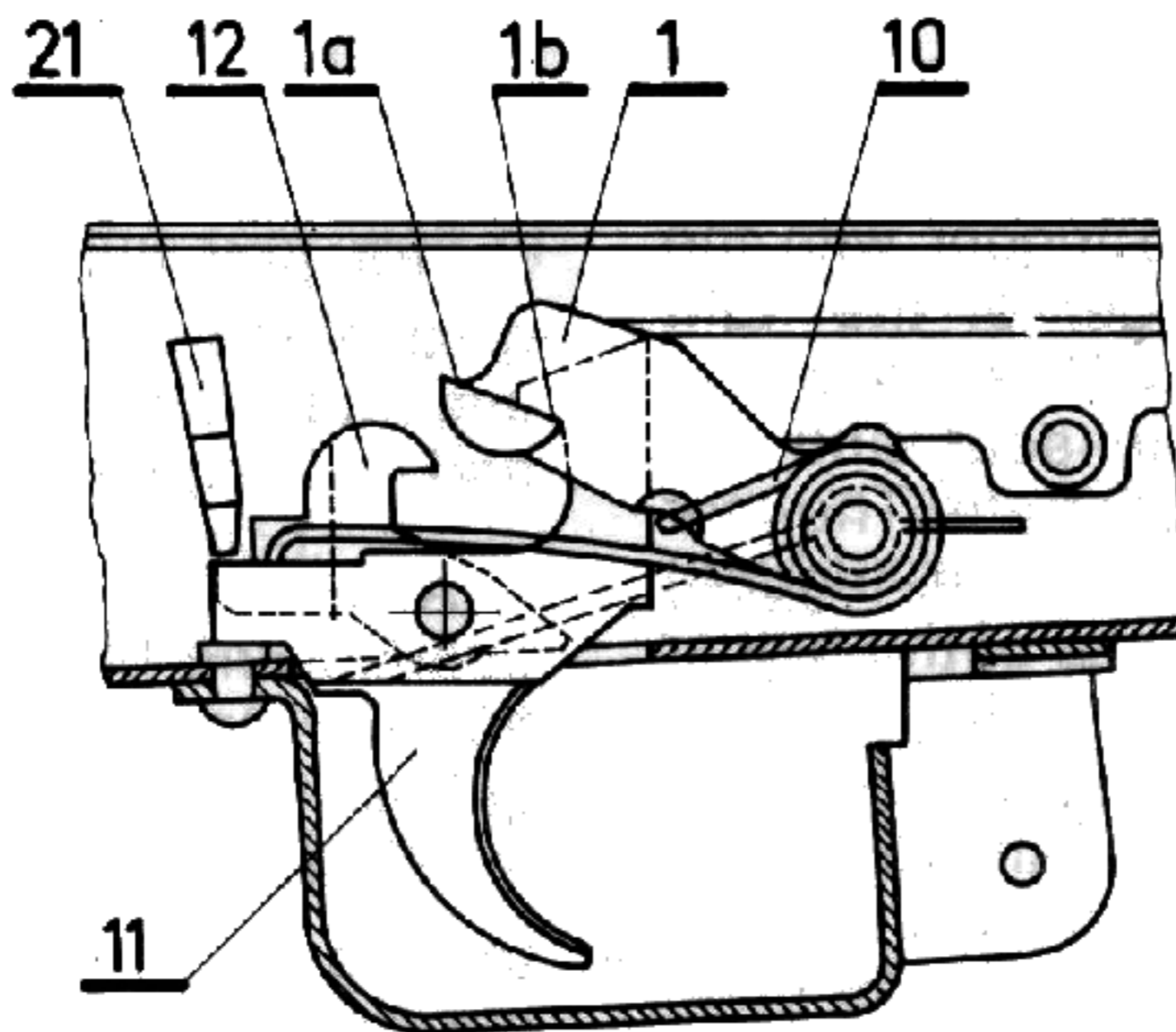

Fig 3- position of parts before loading (vertical section)

- | | | | |
|-------------------|-------------------------------|----------------------|-----------------|
| 1- hammer | 2- bolt | 3- firing pin | 4- bolt carrier |
| 5- return spring | 6- piston | 7- gas cylinder | 8- magazine |
| 9- magazine catch | 10- hammer and trigger spring | 11- trigger | |
| 12- disconnecter. | 13- rear sight leaf | 14- fore sight | |
| 16- hand guard | 17- fore end | 18- accessories case | |
| 19- cleaning rod | 20- barrel | 21- selector lever | |



▶ Fig .4 TRIGGER MECHANISM SET ON SAFETY
 1- HAMMER, 1a- DISCONNECTOR NOTCH,
 1b- HAMMER COCK NOTCH, 10 HAMMER
 AND TRIGGER SPRING, 11- TRIGGER,
 21- SELECTOR LEVER, 12- DISCONNECTOR.

backwards; when the magazine is fully inserted, the magazine catch spring rotates the catch forward again, and the catch engages the stop.

III. FUNCTIONING OF PARTS DURING FIRE:

Press the trigger with the indexed finger of the right hand. When the trigger is pressed, the sear and the disconnecter rotate. The rear end of the sear (i.e. trigger.) raises the ends of the trigger and hammer spring. As the trigger rotates, the sear releases the hammer cock notch. The trigger and hammer spring rotates the hammer forward. The hammer strikes the rear end of the firing pin, thrusting it forcibly until the point of the pin strikes the primer, igniting the primer charge. The flash from the primer charge is transmitted to the propellant charge through ports in the base of the cartridge case.

The powder gases force the bullet to cut it self into the rifling and to move through the bore. After the bullet has

passed the gas port in the barrel, powder gases enter the gas cylinder (7) (Fig. 3) and force the gas piston (6) and the bolt carrier to move to the rear.

As the bolt carrier moves to the rear, the return spring is tensed. The opening bevel in the bolt carrier irregular groove acts on the bolt guide lug, rotating the bolt to the left and opening the breech.

After the breech is opened, the bolt carrier and the bolt move to the rear together, The bolt carrier rotates the hammer to the rear, tensing the hammer and trigger spring. As the hammer rotates, it rotates the disconnecter, when the head of the hammer has passed the notch in the disconnecter, the disconnecter spring forces the disconnecter to engage the disconnecter notch in the hammer. This holds the hammer at full cock.

As the bolt moves to the rear, the extractor pulls the cartridge case out of the chamber. When the case

strikes the ejector, it is ejected from the receiver.

The top round in the magazine is forced upward by the follower until it is arrested by the magazine flange or lip.

The rearward movement of the bolt carrier and bolt is arrested by the rear wall of the receiver. Forward movement of these parts is affected by the energy of the compressed return spring.

As the bolt carrier moves forward, the bolt feed lever extracts the top round from the magazine and pushes it into the chamber.

As the bolt approaches the barrel, the first stage in the rotation of the bolt to the right takes place. At the same time, the extractor engages the groove behind the rim of the cartridge case. As the bolt carrier moves to the extreme forward position, it produces the final rotation of the bolt to the right, sealing the bore.

The next round is fired by releasing the trigger and then pressing it again.

When the trigger is released, the hammer and trigger spring rotates the disconnect and sear to the rear, disengaging the disconnect from the disconnect notch in the hammer. The trigger and the hammer spring (10) (Fig. 5) rotates the hammer (1) until the hammer cock notch (1b) engages the sear. This is accompanied by an audible click.

When the trigger is again pressed, the sear releases the hammer cock notch. The hammer once again strikes the firing pin, and the entire operating cycle of the mechanism is repeated.

IV. FUNCTION OF PARTS DURING UNLOADING:

The rifle is unloaded as follows:

1. Withdraw the magazine.
2. Pull the cocking handle as far to the rear as possible and release it.
3. Set the safety.

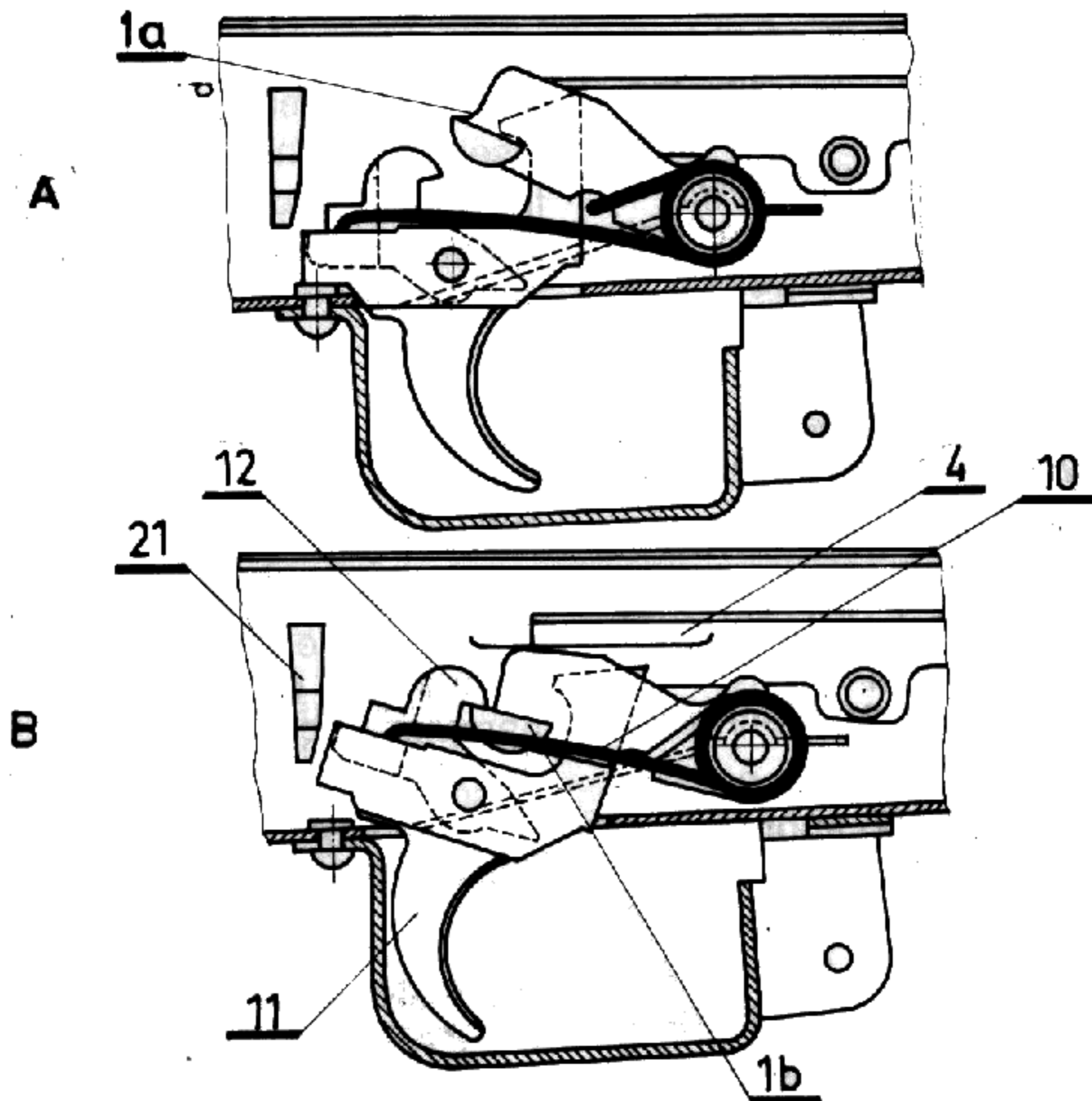

FIG. 5 TRIGGER MECHANISM IN POSITION FOR SEMI
AUTOMATIC FIRE

A- TRIGGER RELEASED

B- TRIGGER PRESSED

1- HAMMER, 1a- DISCONNECTOR NOTCH, 1b- COCK NOTCH,
4- BOLT CARRIER LUG, 10- HAMMER AND TRIGGER SPRING,
11- TRIGGER, 12- DISCONNECTOR, 21- SELECTOR LEVER

As the cocking handle is pulled to the rear, the extractor pulls the cartridge case out of the chamber and holds it against the bolt head. When the base of the cartridge case strikes the ejector, it is ejected from the receiver.

When the cocking handle is released, the return spring returns the bolt carrier and the bolt to the forward position.

When the trigger is pressed, the sear releases the hammer cock notch, the hammer and trigger spring rotates the hammer, which strikes the bolt.

When the safety is set, the parts are in the same positions occupied before loading (see FIG. 4).

Chapter 3

DISASSEMBLY AND ASSEMBLY

I. GENERAL INSTRUCTIONS:

The rifle may be disassembled for cleaning lubrication, inspection and replacement or repair of parts.

The following instructions should be observed during disassembly and assembly

1. The rifle should be disassembled on a table or a bench. In the field, a clean covering should be spread on the ground.
2. The parts should be laid out in order of disassembly.
3. Force should not be used to remove or disassemble parts, as this results in damage to the parts.
4. Only accessories in good conditions should be used.
5. When tightening or loosening screws, the screw driver is to be held firmly in the hand,

6. Before the rifle is disassembled, make sure there is no round in the chamber.

II. FIELD STRIPPING:

1. Remove the magazine from the rifle. Holding the rifle by the fore end with the left hand, rotate the rifle a certain amount, pushing the magazine away, grasp the magazine with the right hand, and depressing the magazine catch with the thumb of the right hand, rotate the magazine forward and remove it from the receiver hole (Fig. 6).
2. Take the rifle off safety. Rotate the selector lever downward as far as possible with the thumb of the right hand.
3. Check to see that there is no round in the chamber. Pull the bolt carrier to the rear and inspect the chamber and the bolt face.

4. Remove the accessories case from the stock. Depress the butt plate cover with the indexed finger of the right hand and remove the accessories case from the stock, remove the accessories from the case.

5. Remove the cleaning rod from the rifle. Place the stock of the rifle on the ground and hold in this position by means of the right hand and, bending it slightly, remove the cleaning rod



FIG. 6 REMOVING THE MAGAZINE FROM THE RIFLE

head from the stop in the base of the front sight, move the cleaning rod upward so that its head leaves the forward face of the front sight, remove the cleaning rod with the right hand (Fig. 7). It is permitted to use a punch to remove the cleaning rod.

6. Remove the receiver cover. Lean the rifle against a table and, holding it by the forward part of the butt with the right hand, depress the guide face with the thumb into the cover hole, raise the cover with the left hand (Fig. 8).

7. Remove the return mechanism from the rifle, Holding the rifle by the forward portion of the receiver with the left hand, move return spring guide forward until its rear face leaves the groove in the receiver rear-plate, lift the guide rear face and remove the return mechanism from the bolt carrier channel (Fig. 9).

8. Remove the bolt carrier with bolt from receiver. Holding the rifle by the forward portion of the receiver with the left hand, and the cocking handle with the

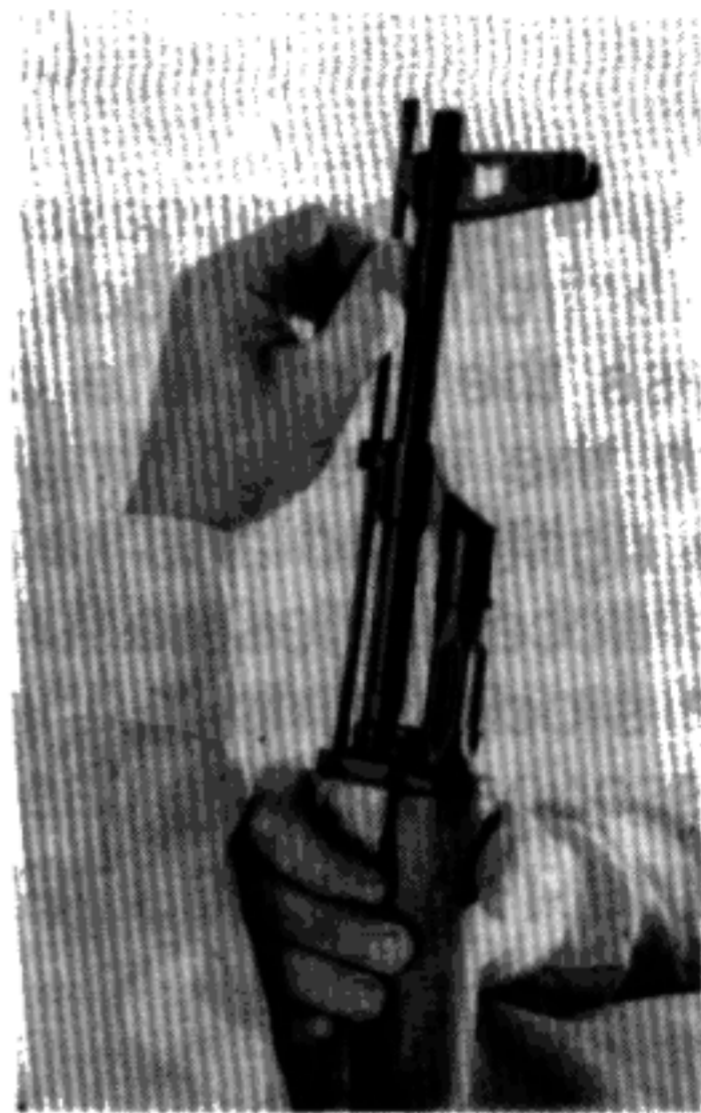

FIG. 7 REMOVING THE CLEANING ROD FROM THE RIFLE

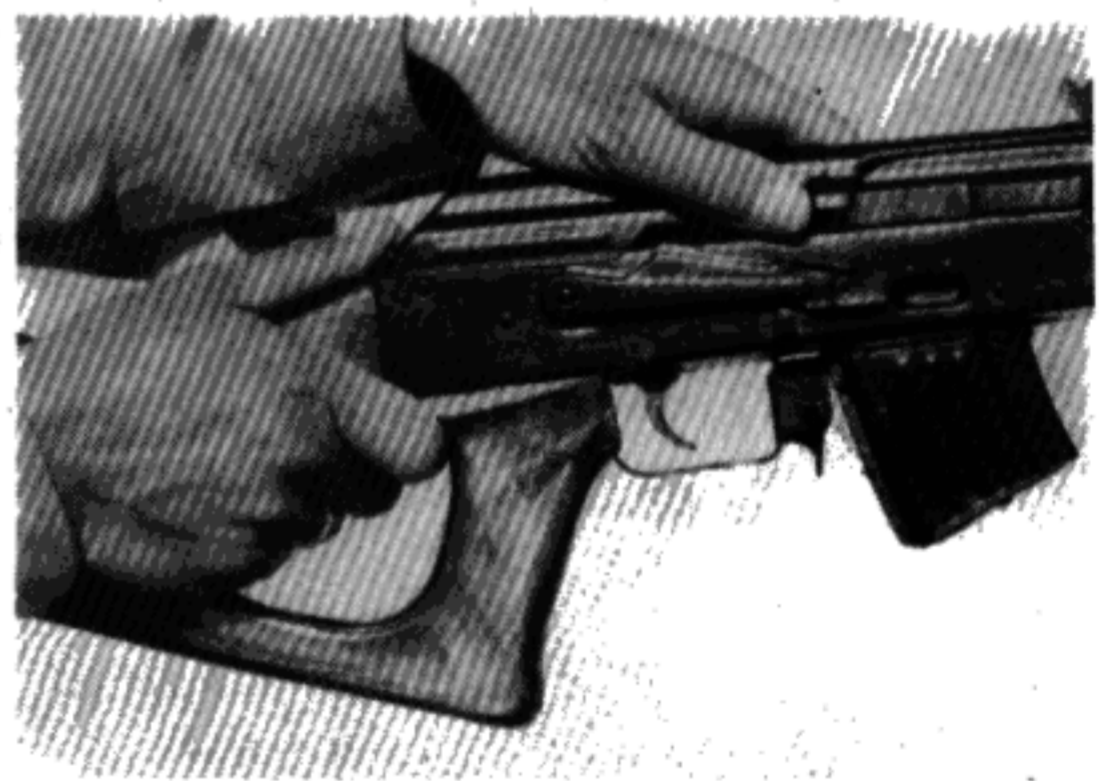

FIG. 8 REMOVING THE COVER FROM THE RECEIVER

right hand, bring the bolt carrier with bolt to the rear as far as possible, and moving the bolt carrier forward a distance of 1 to 2 mm .,

Lift the rear portion of the bolt carrier and remove it together with bolt from the receiver

9. Remove the bolt from the bolt carrier. Take the bolt

carrier in the left hand with the cam surface facing upward, and rotate the bolt a small amount with the right hand so that the guide lug leaves the wide part of the variable groove in the bolt carrier and then move the bolt to the rear as far as possible, rotating the bolt, remove its lug from the variable groove of the bolt carrier and remove the bolt



FIG. 9 REMOVING THE RETURN MACHANISM FROM THE BOLT CARRIER

from the bolt carrier by moving it forward. (Fig. 10).

10. Remove the gas tube with hand guard from the barrel. Holding the rifle by the forward portion of the receiver with the left hand, rotate the lock lever upward with the right hand, rotate the gas tube upward by means of the rear end of the receiver and remove it from the gas cylinder.

III. ASSEMBLY AFTER STRIPPING:

The rifle is assembled after field stripping in reverse order:

1. Attach the gas tube with hand guard to the barrel. Holding the rifle by the forward portion of the receiver with the left hand, install the gas tube on the gas cylinder with the right hand and depress the rear end of the gas tube as much as possible, rotate the gas tube lock downward so that the lever lock enters the recess in the right wall of the rear sight base.
2. Attach the bolt to the bolt carrier. Grasp the bolt carrier with the left hand with

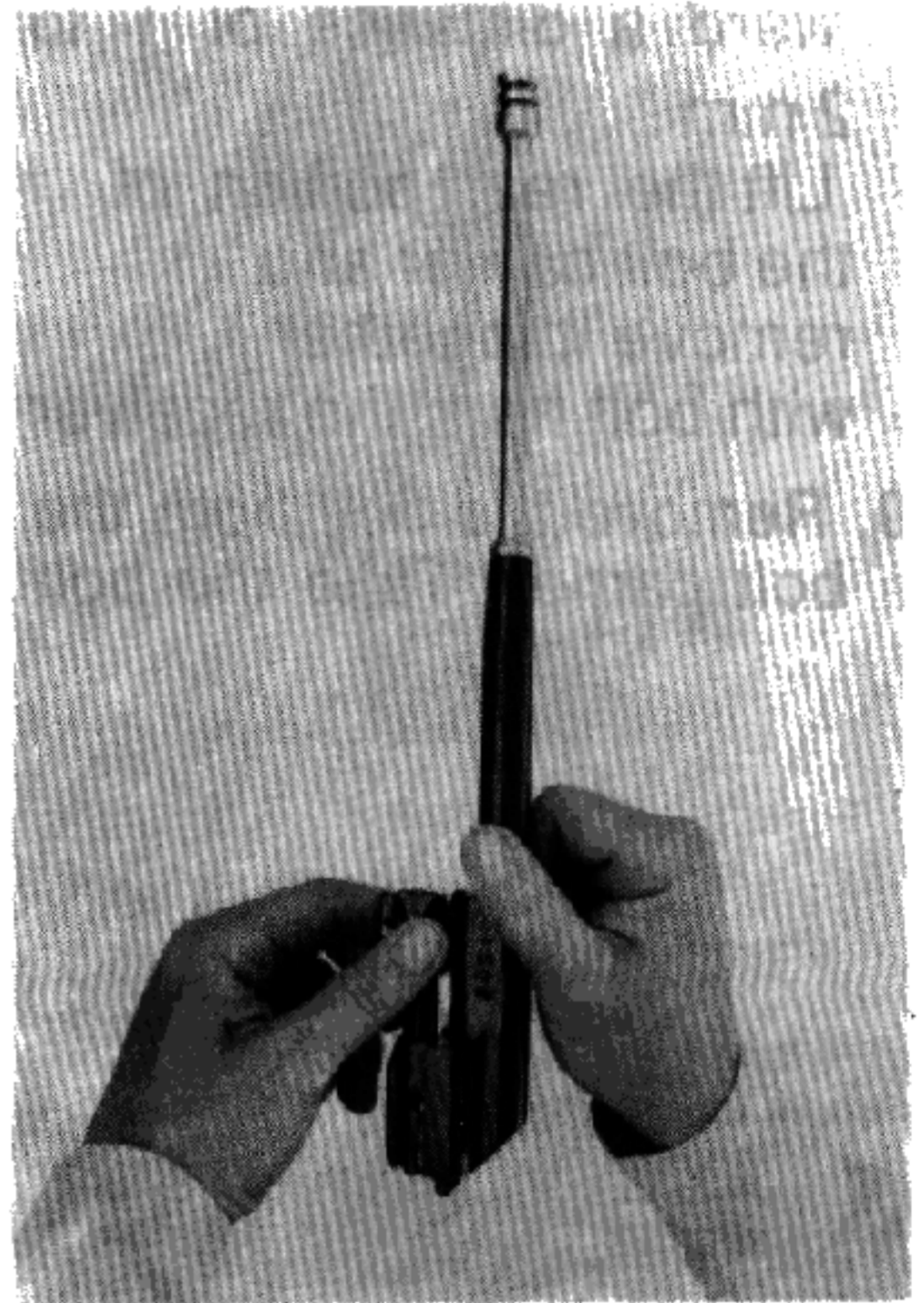

FIG. 10 REMOVING THE BOLT FROM THE BOLT CARRIER

the cam surface upward, and with the right hand install the bolt in the bolt carrier lug, rotate the bolt so that the guide edge enters the variable groove in the bolt carrier, and then move

the bolt forward.

3. Install the bolt carrier with bolt in the receiver. Hold the rifle by the forward portion of the receiver with the left hand, and with the thumb of the right hand, hold the bolt in the forward position, then insert the piston into the gas tube and insert the bolt carrier with the bolt into the receiver so that the guide luge of the bolt carrier and the lugs

of the bolt are opposite the notches in the guide on the receiver, depress the rear portion of the bolt carrier so that its guide grooves coincide with the guides of the receiver, and move the bolt carrier to the extreme forward position (Fig. 11).

4. Install the return mechanism in the bolt carrier. Hold the rifle by the forward portion of the receiver with the left hand, and with the



FIG. 11 ATTACHING THE BOLT CARRIER WITH THE BOLT TO THE RECEIVER

right hand insert the return mechanism into the bolt carrier channel, move the return mechanism rear face forward and, placing its guide lugs opposite the grooves in the receiver rear plate, depress the return mechanism rear face, in this position, the rear faces should enter the groove in the receiver rear plate.

5. Install the cover on the receiver. Hold the rifle by the forward portion of the receiver with the left hand, and with the right hand insert the cover so that its forward face enters the semicircular groove in the rear sight base and move the cover forward as far as possible, press the rear portion of the cover forward and downward, thus completing the installation.
6. Install the cleaning rod in the rifle.
7. Insert the accessories into the case and insert the case into the recess in the butt.

8. Install the magazine on the rifle. Hold the rifle by the fore end with the left hand, and rotate the rifle a certain amount, insert the upward forward portion of the magazine into the opening in the receiver with the right hand so that the magazine front stop enters the notch in the receiver, rotate the magazine to the rear so that the magazine catch is engaged by the magazine rear stop (Fig. 12).

9. Release the hammer from the semiautomatic sear, and turn on the safety, rotating the selector lever upward.

IV. DETAIL STRIPPING:

Detail stripping of the rifle is a continuation of field stripping. It is performed in the following manner: Field strip the rifle as instructed in sec II, and then perform the following:

1. Disassemble the return mechanism.

Place the return mechanism against a table. Compress the return spring with



FIG. 12 ATTACHING THE MAGAZINE TO THE RIFLE

the left hand and remove the collar from the front guide rod with the right hand (Fig. 13). Remove the spring and the front guide rod.

2. Disassemble the bolt.

Grasp the bolt with the left hand with the feed lever upward, and with the right hand remove the firing pin pin from the bolt body using a punch. Remove the firing pin from the bolt.

Holding the extractor with the thumb of the left hand, remove the extractor pin, using a punch. Remove the extractor and extractor spring from the recess in the bolt body.

3. Disassemble the firing and trigger mechanism.

Remove the locating trigger and hammer axles spring, using a punch. Punch the trigger pin to the left, using a punch, then remove the trigger with disconnect and spring from the receiver. Separate the disconnect from the trigger and remove the semi-automatic sear spring from its recess. Punch out the hammer pin to the left, by

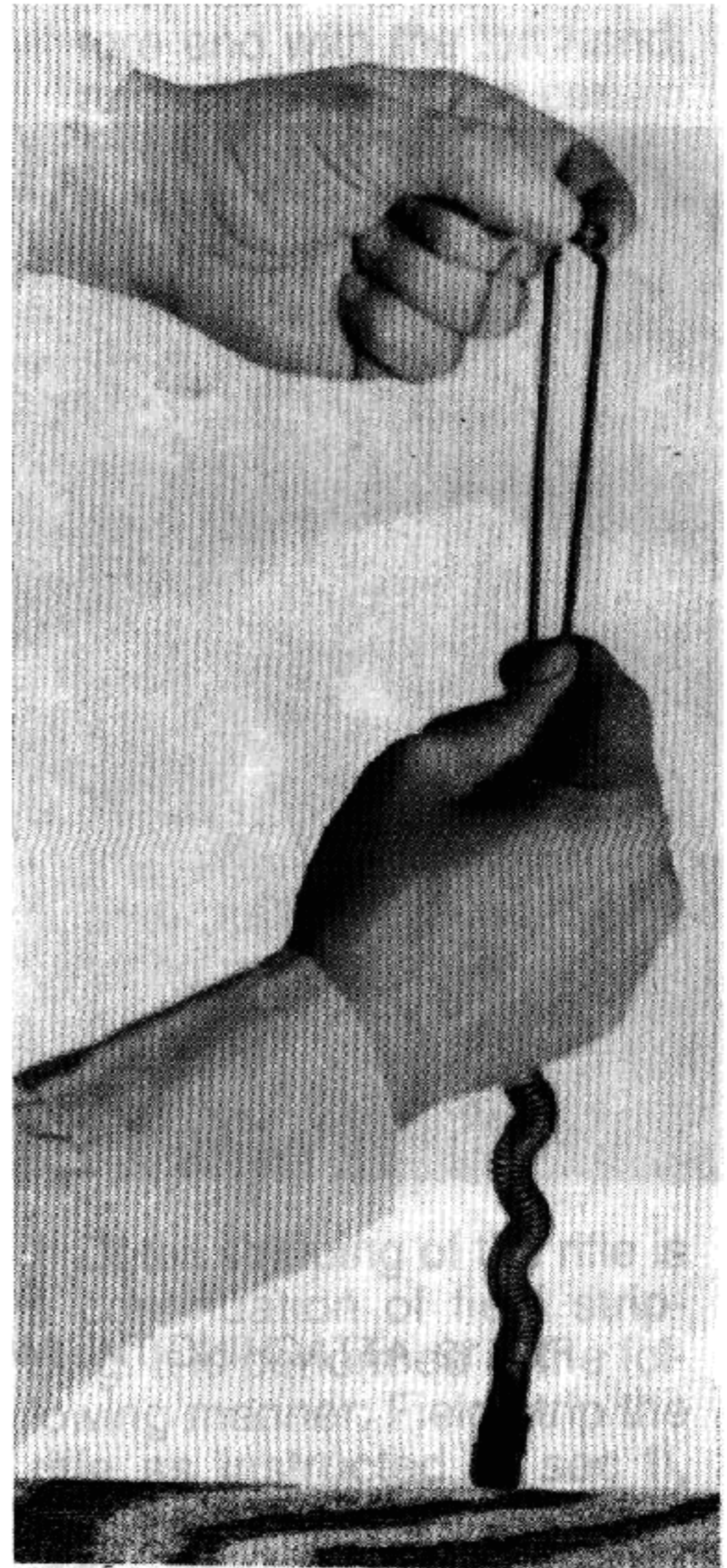

FIG. 13 DISASSEMBLY OF THE RETURN MECHANISM

means of a punch, remove the hammer and trigger spring from the receiver. Rotate the selector indicator upward until the lug on the lever coincides with the notch in the wall of the receiver hold, and separate the selector from the receiver.

NOTE:

The firing and trigger mechanism may be disassembled by a certified armorer only, for the purpose of repair or replacement of parts.

4. Remove the fore end from the barrel. Hold the forward portion of the hand guard with the left hand, and with the right hand rotate forward as far as possible the foreend band lock lever by means of a punch, and move the stop hand towards the gas cylinder. Move the fore end forward with the right hand so that its lug on the rear face is disengaged from the recess in the receiver, and then disengage the fore end by pulling downward.

V. ASSEMBLY AFTER DETAIL STRIPPING:

1. Attach the fore end to the barrel. Hold the rifle by the forward portion of the receiver with the left hand, and with the right hand insert the fore end so that its lug on the rear face enters the recess in the receiver, and move the fore end forward as far as possible. Mount the band on the fore end shoulder as tightly as possible and rotate the lock to the rear so that its indicator enters the notch on the band. If the lock lever does not rotate to the rear, it is necessary to move the band along the barrel, and at the same time to press upward on the lock lever, in this manner aligning the lock with the recess in the barrel, and then rotate the lock.
2. Assemble the firing and trigger mechanism. Mount the hammer and trigger spring on the hammer pin and insert the hammer with hammer and trigger spring into the receiver. Insert the punch in the hole for the hammer pin from the right

side of the receiver. Insert the hammer pin into the hole through the left side of the receiver, while removing the punch, insert the hammer pin.

Assemble the selector to the receiver and set it to the fire position. Install the disconnect spring and the spring spacer into the trigger groove and insert the trigger into the hole in the receiver. Through the right side of the receiver, insert the punch into the hole for the trigger pin.

Insert the trigger pin into the hole through the left side of the receiver, while removing the punch, install the trigger pin.

Install the trigger and hammer axles spring, placing it into the recess of the trigger axle and hammer axle using a punch.

Raise the ends of the hammer and trigger spring by means of the punch and place the bent ends of the spring on the rear shoulders of the trigger.

3. Assemble the bolt. Insert the extractor and its spring

into the bolt recess, depress the extractor with the thumb of the left hand to set it in the recess, set the extractor pin in the hole with the right hand so that the notch on the upper end of the pin is turned in the direction of the rear cylindrical position of the bolt body.

Insert the firing pin into the bolt so that the recess in the firing pin is aligned with the hole for the pin, in order to control the position of the firing pin in the hole for the firing pin retaining pin, it is necessary to insert the punch from the side of the feed lever so that the firing pin can rotate and interfere with the installation of the firing pin retaining pin.

4. Assemble the return mechanism. Insert the operating and front part into the recoil spring rod assembly. Install the return spring. Compress the return spring with the left hand, and with the right hand install the collar on the operating rod front part.

VI. DISASSEMBLY OF THE MAGAZINE:

Remove the cover plate from the magazine. Grasping the magazine in the left hand depress the stop (Fig. 14) by means of the punch (through the hole in the cover) and move the cover plate so that the stop lug is disengaged from the hole in the cover plate, hold the stop plate with the thumb of the left hand and remove the cover plate with the right hand. Remove the stop plate with spring and follower from the magazine, release the stop plate and remove the spring together with the stop plate and follower from the magazine. Remove the follower and stop plate from the spring.

VII. ASSEMBLY OF THE MAGAZINE:

Assemble the follower and stop plate to the spring. Insert the spring with follower and stop plate in the magazine. Grasp the magazine with the left hand (cover plate upward, rear groove inward),

and with the right hand insert the spring with the follower and stop plate in the magazine (Fig. 15). Attach the cover plate to magazine. Depress the stop plate in the magazine body and holding it with the thumb of the left hand, move the cover plate onto the flanges of the magazine body with the right hand until the lugs of the cover plate press against the rear wall of the magazine.

VIII. DISASSEMBLY AND ASSEMBLY OF THE RIFLE IN REPAIR SHOP:

In addition to detail and field stripping and assembly, disassembly and assembly of the sights and the butt are also performed in the repair shop.

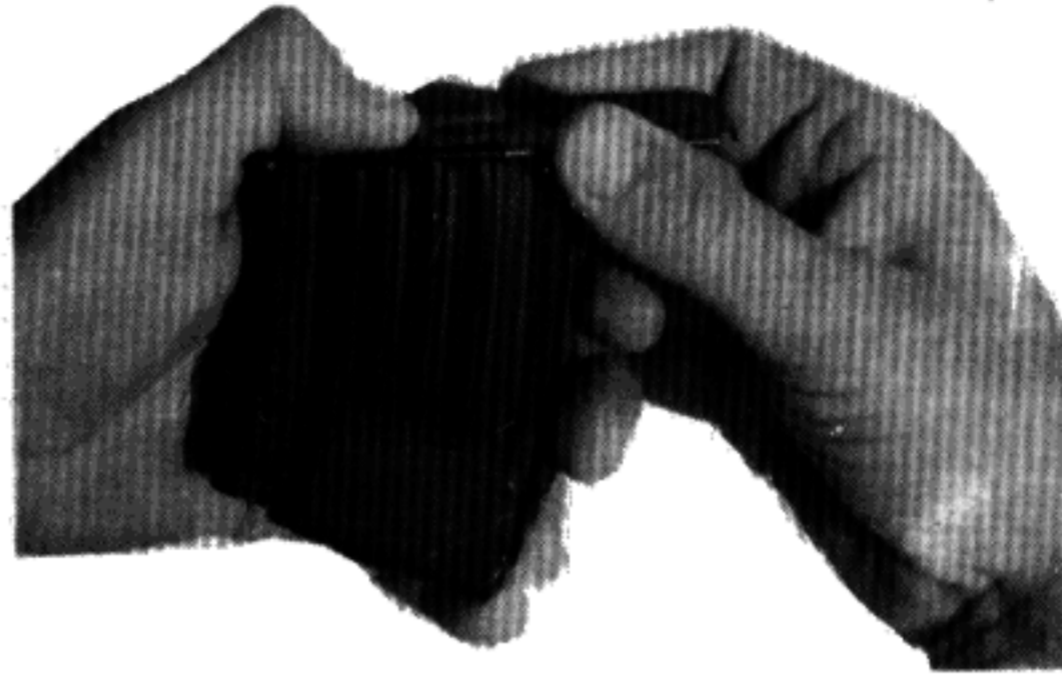

**FIG. 14 REMOVING THE COVER PLATE FROM
THE MAGAZINE**

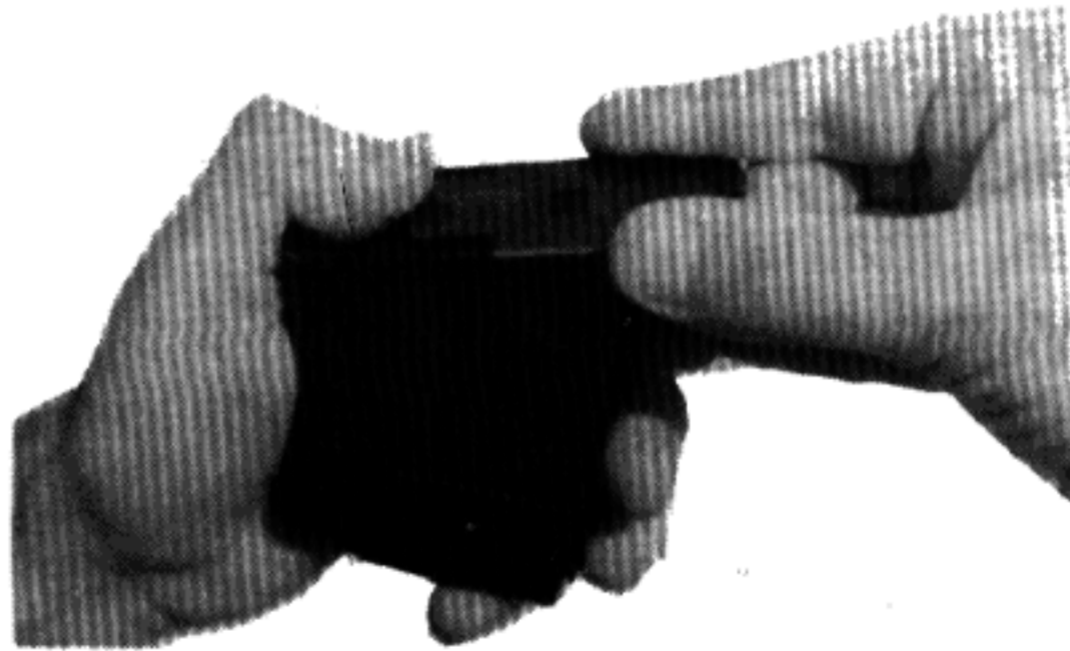

**FIG. 15 INSTALLING THE SPRING WITH THE FOL-
LOWER AND STOP PLATE TO THE MAGAZINE**

DISASSEMBLY

1. **Disassemble the wooden butt.** Unscrew the screws which connect the butt with the receiver. Knock the butt out of the receiver. Unscrew the screws in the butt plate with the screw driver, and remove the butt plate and cover plate from the butt.
2. **Remove the front sight.** Hold the rifle by the barrel with the left hand. Unscrew the front sight by rotating the screw driver in the counter-clockwise direction.
3. **Remove the fore sight bar from the front sight base.** Place the muzzle of the rifle on a table or wooden stand and knock out the fore sight bar using a punch or wooden rod.

NOTE: The front sight and the fore sight bar are to be removed only for repair. After installing it is necessary to check the accuracy of the rifle.

4. **Disassemble the rear sight.** Hold the sight leaf at an angle of 40° to 50° and press on the forward end of the sight leaf using a punch or wooden rod, and move the sight leaf to the rear until the pins leave the holes in the rear sight base lug. Using a punch and hammer, knock out the sight leaf spring from the grooves in the sight base, and remove the spring from the sight base. Press on the slide catch, move the slide along the sight leaf and remove it, and remove the catch and the catch spring from the recess in the slide.

ASSEMBLY

1. Assemble the rear sight. Insert the catch spring and the catch into the slide recess and while pressing on the catch, install the slide on the sight leaf and move it to the rear as far as possible. Install the sight leaf spring in the rear sight base grooves holding the sight leaf at an angle of 40° to 50°. Place the forward end of the sight leaf on the spring and, pressing on the forward end with a punch or wooden rod, move the sight leaf forward so that its pins enter the holes in the rear

sight base lugs. Free the forward end of the sight leaf after releasing the pressure on it.

2. Assemble the front sight. Insert the fore sight bar into the base hole until the alignment marks coincide. Screw the front sight into the fore sight bar using screw driver.

3. Assemble the wooden butt. Insert the accessory case spring into the recess in the butt. Attach the butt plate cover and the butt and replace the screws. Attach the butt to the receiver and screw them.

CHAPTER 4

CAUSES OF FAILURE OF THE RIFLE

1. GENERAL PROCEDURE FOR PREVENTING AND ELIMINATION OF STOPPAGES:

With proper maintenance, storage and handling; the rifle is reliable in use. However, as a result of careless handling, dirty parts, low-grade rounds, and also as a result of wear of the parts caused by extensive use, normal operation of the rifle can be affected, causing stoppages during fire. The majority of stoppages can be easily eliminated simply by cocking the rifle that is by bringing to the rear the bolt carrier and releasing it.

TO PREVENT STOPPAGES :

1. Prepare the rifle for firing properly.
2. Inspect, clean and lubricate the rifle
3. Carefully observe the cleanliness and operation of bolt carrier, bolt, gas channels and magazines.
4. Perform timely maintenance.
5. Carefully inspect ammunition before firing.
6. Fire only serviceable and clean ammunition.
7. Protect the rifle from dirt and blows during fire and travel.
8. Disassemble and clean the rifle whenever it is excessively dirty. If the rifle is used in extremely cold weather a considerable period of time, before loading it is necessary to move the bolt carrier forward and rearward several times manually.

If a stoppage occurs whereas a chambered round fails to fire, continue to point the rifle in a safe direction and wait approximately 30 seconds. This is to avoid possible delayed detonation of a "hangfire" type malfunctioning cartridge. Recock the rifle, thus extracting faulty round and chambering a fresh round. If rifle fails to fire again, follow steps to unload rifle and ascertain cause of stoppage.

II. CHARACTERISTIC MALFUNCTIONS AND METHODS FOR CLEARING THEM

A list of the common malfunctions is given in the following table, together with the general causes of the malfunctions and the simplest method that may be employed to clear them

MALFUNCTION	CAUSES	TO CLEAR
1- Failure of magazine to feed rounds. The moving parts move to the extreme forward position, the round is not fired, and there is no round in the chamber.	Magazine not properly attached. Dirty or defective magazine. Defective magazine catch.	Recock the rifle and continue fire, if the malfunction occurs again, replace the magazine. If magazine catch is defective, send the rifle to the repair shop.
2- Empty cartridge case not extracted from chamber. Cartridge case remains in chamber, the following round jams against the cartridge case. Moving parts remain in centre position.	Dirty rounds or chamber, defective extractor or weak extractor spring.	Cock rifle and remove cartridge case from chamber clean rounds and chamber, and inspect the extractor. If the extractor is serviceable, continue firing, If the extractor is unserviceable, send rifle to the repair shop

MALFUNCTION	CAUSES	TO CLEAR
<p>3- Jamming of cartridge case, cartridge case not extracted from receiver, but is jammed between bolt and barrel or between bolt and receiver or is rammed back into chamber.</p>	<p>Dirty moving parts, gas port or chamber. Defective extractor extractor spring.</p>	<p>Pull bolt to rear, extract jammed cartridge case and continue firing. Clean and lubricate rifle at first opportunity. If extractor or extractor spring is defective, send the rifle to repair shop.</p>
<p>4- Jamming of round . The bullet end of round jams against the barrel as the bullet moves forward.</p>	<p>Excessive play of magazine, bent magazine flanges.</p>	<p>Pull bolt carrier to the rear and, retaining it by means of the cocking handle, remove the jammed round and continue firing if jamming occurs again, replace magazine.</p>
<p>5- Misfire. bolt in forward position, hammer released, but round not fired.</p>	<p>If the primer shows deep dents caused by firing pin, primer is defective. If slight dent is found in primer, defect lies in firing pin or firing and trigger mechanism.</p>	<p>Wait approximately 30 seconds to avoid possible delayed detonation of a "hangfire" type malfunctioning cartridge. Recock the rifle, thus extracting faulty round and chambering a fresh round . If stoppage occurs often inspect and clean firing pin and firing and trigger mechanism. if the parts are broken or defective, send rifle to repair shop.</p>

CHAPTER 5

CLEANING AND LUBRICATION OF THE RIFLE IN USE

1. GENERAL:

The rifle must be kept clean at all times. Cleanliness is attained by timely and proper inspection, cleaning, and lubrication. Cleaning of rifles in use in units is performed:

1. After firing service and blank cartridges immediately upon completing the fire. It is necessary to apply the alkali solution, wipe dry and lubricate the bore, gas cylinder, gas tube, piston and bolt immediately at the firing range (in the field), upon returning from the firing range, the rifle must be cleaned completely; cleaning must be repeated for the following three or four days.
2. After training, guard duty and exercises (even though the rifle is not fired) immediately after completing duty.
3. If the rifle is not fired or used-not less than once every seven days

NOTE:

It is strictly forbidden to leave alkali solution in the bore, gas cylinder, gas tube or bolt face, since this will cause rapid rusting of the metal.

The rifle is lubricated immediately after cleaning.

In permanent installations, the rifles are cleaned in places which are specially prepared. For cleaning; in the field the rifles are cleaned in places which are prepared laying down boards, canvas etc.

The material for cleaning must be in good condition, and the lubricating materials must be of good quality. The

lubricating materials must be stored in the proper cans and the cloths in bags. Lubrication must be lightly wrapped.

For cleaning, wiping and lubrication of the rifle, use a clean and soft patch and hemp fiber from which the

scutch is removed. The hemp is used for cleaning the bore.

To clean and lubricate the rifle, use the following lubrication and cleaning compositions:

1. Alkali solution, removes fouling from the bore and other parts of the rifle which come into contact with the gases.
2. Rifle lubricating oil, this is used for lubricating all metal parts, and is effective at a temperature of -5°C . to $+50^{\circ}\text{C}$

Winter lubrication No. 21, this is used for lubricating rifles which are in use in winter, both in preparation for fire and in lulls in fire. Winter lubrication No. 21 is effective for use in the mechanisms of the rifle at a temperature of -5°C to 40°C .

3. Gun oil, used to lubricate the rifle prior to extensive storage, it is used with rifle lubricating oil (50% gun oil and 50% rifle lubricating oil).

4. Kerosene of good quality which is first filtered with calcined table salt; used to remove old lubrication from rifle (after storage), for softening rust, and also for diluting winter lubrication No. 21. Kerosene may be used only in the artillery repair shop.

II. PROCEDURE FOR CLEANING AND LUBRICATION:

To clean the rifle after firing, exercises and duty detail, the rifle must be field stripped.

The rifle must be detail stripped to remove storage lubrication, when replacing or repairing parts, when the rifle is very dirty, or after excessive exposure to moisture.

To clean the bore, the accessory case must be attached to the cleaning rod as follows:

1. Insert the cleaning rod through the large hole in the case so that its head passes inside the case and butts against its wall.
2. Insert the screw-driver into

the case above the cleaning rod head.

3. Install the accessory case cap on the cleaning rod.
4. Install the jag or brush on the threaded end of the cleaning rod as shown in Fig. 16.

**FIG. 16 CLEANING
ROD PREPARED
FOR CLEANING
THE BORE**



When using the tool as a key for removing or installing the front sight, the screw driver blade is inserted into the

notches in the accessory case (through the long notch and the short notch).

When using the tool as a screw-driver, the key is inserted into the accessory case notches (through the long notch into the short notch).

To clean the bore, it is necessary to form the hemp fiber into a figure eight and immerse it into the alkali solution, and install the hemp fiber on the face of the jag in such a manner that its ends do not hang further than the rotating part of the jag. Then introduce the cleaning rod into the bore through the muzzle end to a depth of approximately one third the length of the barrel, install the accessory case cap on the muzzle part of the barrel, rest the butt plate against an object grasp the barrel with the left hand, and grasp the accessory case (cleaning rod handle) with the right hand, and move the cleaning rod

back and forth throughout the entire length of the bore to 10 times, then replace the hemp fiber with other hemp fiber saturated with alkali solution and repeat the process. Dry the bore thoroughly using a patch (after carefully wiping the cleaning rod, jag and accessory case cap) and if there are traces of fouling or rust on the patch, repeat the cleaning using the hemp fiber saturated with alkali solution, and then use a dry white patch. Repeat this operation until a dry white patch shows no traces of fouling.

The same procedure is to be employed to clean the chamber, gas cylinder, and muzzle face. After cleaning the bore, chamber, and gas cylinder, inspect the bore through the muzzle and while rotating the rifle. To improve illumination, insert a piece of white paper into the receiver.

NOTE:

A barrel in which there is an erosion pattern must be cleaned especially carefully, and all the erosion must be removed.

After the bore and chamber are cleaned, they are lubricated with a uniform thin layer of oil, using the brush dipped in rifle lubricating oil. If the brush is unsuitable, it is permitted to lubricate the bore using the patch dipped in rifle lubricating oil.

The exterior surface of the barrel (the areas under the hand guard, fore end and rear sight base) should be cleaned with a patch soaked in alkali solution wrapped around the end of a small wooden stick.

If the rifle has been fired, the gas cylinder and gas tube should also be cleaned with a patch soaked in alkali solution until all carbon deposits are removed, after which the parts should be dried with a patch wrapped around the wooden stick or around the jag. The gas port should be cleaned with a reamer.

After firing, the piston, the gas piston rod, bolt and bolt carrier are cleaned with a patch saturated with the alkali solution. It is forbidden to clean the bolt carrier channel in which the return mechanism is housed using the alkali

solution; it must be wiped dry, using a clean patch and lubricated by applying a patch saturated with rifle lubricating oil.

If the rifle has not been fired, the gas cylinder, gas tube, piston, gas piston rod bolt carrier must be wiped dry with a clean patch and lubricated.

If a hardened fouling is present in the above indicated parts, apply the alkali solution to them and remove the solution after a period of ten to fifteen minutes, then clean and dry them thoroughly. The receiver, return mechanism, firing and trigger mechanism are wiped using a dry cloth; the holes, recesses and grooves are cleaned with a patch on the end of a sharp stick. After cleaning, the rifle parts must be covered with a thin layer of rifle lubricating oil.

NOTE:

The firing and trigger mechanism are not disassembled for cleaning and lubrication.

After cleaning, a check

must be made that no patches are left in the gas port and bolt carrier channel.

It must be borne in mind that excess lubrication tends to collect dirt. In the summertime, moving parts must be lubricated more than often in winter.

The exterior surface of metal parts must first be wiped with a clean cloth and then with a cloth bearing a small amount of oil, wooden parts of the rifle are to be wiped, using only a dry cloth; it is forbidden to lubricate them with rifle lubricating oil.

To lubricate holes, recesses, and grooves, a clean patch must be wound on a wooden rod and dipped into oil.

If magazines were filled with rounds but the rifle has not been fired, wipe only the exterior surface of the magazines and apply a thin layer of lubricating oil, if the magazines were filled and the rifle was fired, the magazines must be disassembled. All the parts must be wiped with a dry patch on the end of sharp stick, and feed mechanism and followers wiped with a

cloth dipped in alkali solution, and then dried using a dry patch and coated with a thin layer of oil.

Upon completion of cleaning, the accessories must be wiped, inspected, assembled and inserted into the butt, after lubrication the rifle is assembled, the operation of the parts in assembled form is checked.

III. CLEANING AND LUBRICATING RIFLES IN PREPARATION FOR EXTENDED STORAGE:

Rifles to be cleaned in preparation for storage must be detail stripped, the usual cleaning procedures are to be observed, with special attention allotted to the removal of carbon deposits, dirt, moisture and rust from the bore, gas cylinder, gas tube, gas piston, and all grooves and holes.

To remove traces of rust and lubrication, it is suggested that the parts of the rifle be taken to an artillery repair shop and washed in kerosene, then dried thoroughly with a

clean dry patch; then lubrication must be applied immediately to protect the metal from moisture.

The dried parts must not be handled in the bare hands, since rust may form from perspiration. They must be handled using a clean patch or paper.

After being cleaned and dried; they should be lubricated with a mixture consisting of 50% rifle lubricating oil and 50% gun oil.

The wooden parts of the rifle are dried thoroughly and are not lubricated.

Rifles in storage (both new and used) are inspected and cleaned not less than once every two years; the oil in the bores must be changed at least once every two years, and fresh lubrication applied to exposed parts not less than twice a year

MAADI CO. FOR ENGINEERING INDUSTRIES

MAADI - CAIRO EGYPT

FINAL INSPECTION CERTIFICATE FOR FIREARMS

AND ITS COMPONENTS

Item : ARM SEMI AUTOMATIC RIFLE

Cal. 7,62 x 39 mm

Quantity : ONE RIFLE No. AC ~~0057400~~

Maadi Company guarantees that the above item is manufactured from best materials and inspected according to Army technical inspection conditions.

Date 11 / 1 / 1995

For / *Sayed*

Maadi Co. For Engineering Industries

