

Poly Technologies

Legend

S E R I E S

O W N E R S M A N U A L

MODEL: AK-47/S

Poly Technologies

Legend

S E R I E S

**MODEL AK-47S RIFLE
CALIBER 7.62 x 39mm**

OWNER'S MANUAL



PLEASE READ THIS INSTRUCTION MANUAL AND UNDERSTAND THE STATED WARNINGS BEFORE USING THE FIREARM

THIS INSTRUCTION MANUAL SHOULD ACCOMPANY THIS FIREARM AT ALL TIMES AND BE TRANSFERRED WITH THE FIREARM UPON CHANGE OF OWNERSHIP.

THE INSTRUCTION MANUAL FOR EACH POLY TECH FIREARM IS AVAILABLE FROM THE IMPORTER ON REQUEST. THESE INSTRUCTION MANUALS CONTAIN IMPORTANT WARNINGS WHICH MUST BE UNDERSTOOD AND ABIDED BY THE USER OF THE FIREARM. FOR INFORMATION ON HOW TO OBTAIN THE INSTRUCTION MANUAL FOR YOUR POLY TECH FIREARM, CONTACT THE IMPORTER AT THE ADDRESS PRINTED ON THE REAR COVER.

TABLE OF CONTENTS

	Page
General	1
Functioning	2
Technical data.	3
Operation and handling precautions	7
Warnings and disclaimers	9
Handling and operation	
Safety lever.	11
Loading	12
Chambering a round.	13
Unloading.	14
Bayonet	15
Blank firing device	16
Zeroing the rifle	17
Sling	18
Preparation for disassembly	19
Disassembly	20
Reassembly	22
Use of cleaning kit.	23
Cleaning	25
Magazine disassembly	26
Parts list	27

GENERAL INFORMATION

The Poly Tech AK-47S is a gas operated, magazine-fed, semi-automatic rifle. It is a civilian version of the Soviet designed AK-47 (*Avtomat Kalashnikova*) assault rifle. This weapon has been used by numerous countries as a standard infantry arm and is widely-renowned for its reliability in severe conditions. Even though the basic design of the AK-47 has been around for more than four decades, it has still yet to be surpassed by newer designs in the critical area of reliability.

The Poly Tech AK-47S is a near-exact copy of the AK-47 (Third Model). Its receiver is of the forged and machined type rather than the stamped and riveted type. Only top-quality materials have been used in its construction to assure its owner of many years of trouble-free shooting enjoyment.

FUNCTIONING OF THE AK-47S

The gas system of the AK-47S uses gas (trapped from the barrel after a round is fired) to drive the gas piston and bolt carrier assembly to the rear (as shown in Fig. 1).

The bolt carrier, on its rearward stroke, rotates and unlocks the bolt (see Fig. 2 and 3) and cocks the hammer. The extractor pulls the fired case and holds it against the bolt face until the case strikes the ejector and is thrown to the right side of the shooter.

The recoil spring returns the bolt carrier forward. The bolt pushes the next cartridge from the magazine into the chamber. As the bolt carrier moves forward, the bolt rotates into its locked position.

When the safety lever is placed on "FIRE," the pivoting arm of the lever moves to the rear, thus allowing the trigger to disengage the hammer (see Fig. 4). By moving the safety lever to the "SAFE" position, the pivoting arm moves in and blocks the trigger (see Fig. 5).

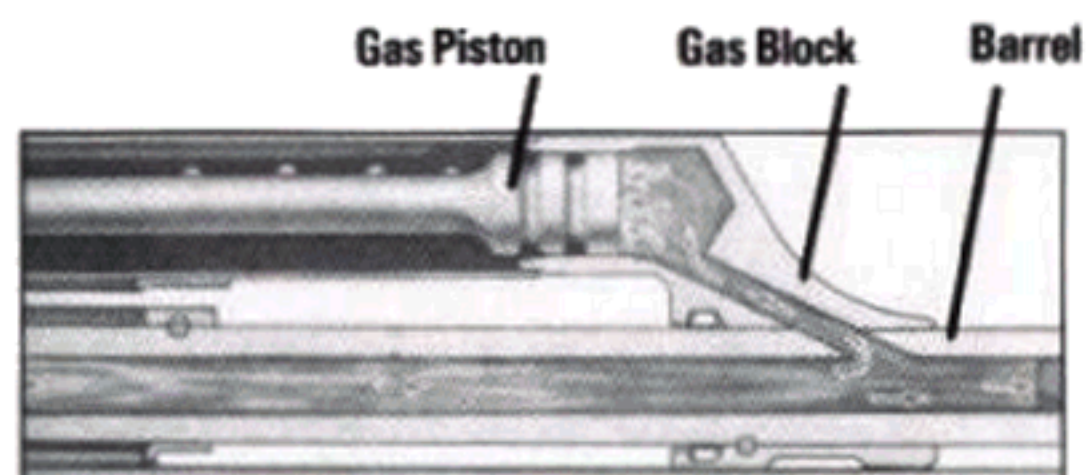

Fig. 1 The gas system of the AK-47S

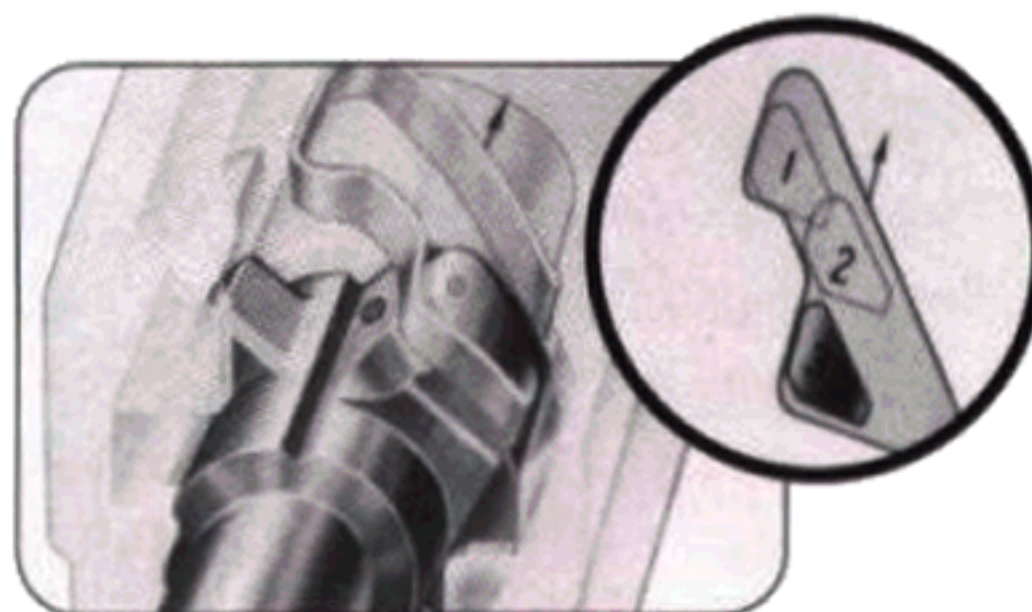

Fig. 2 The bolt shown in locked position

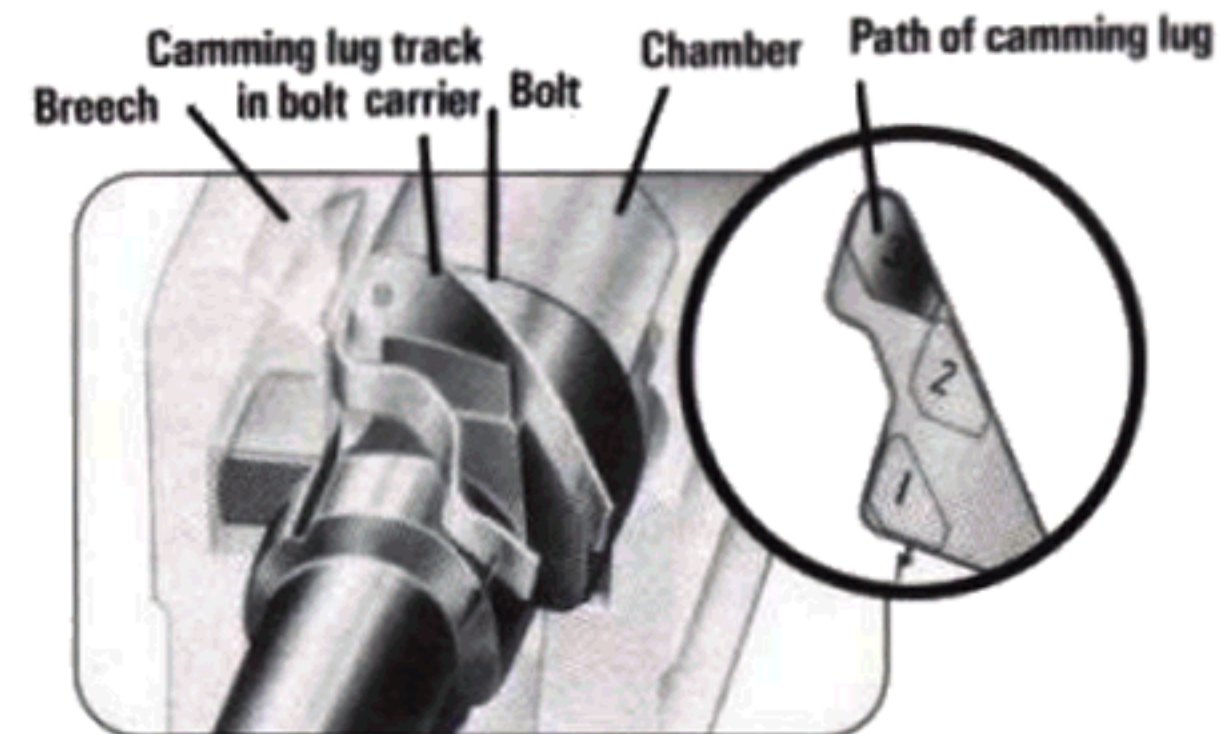

Fig. 3 The bolt shown in unlocked position

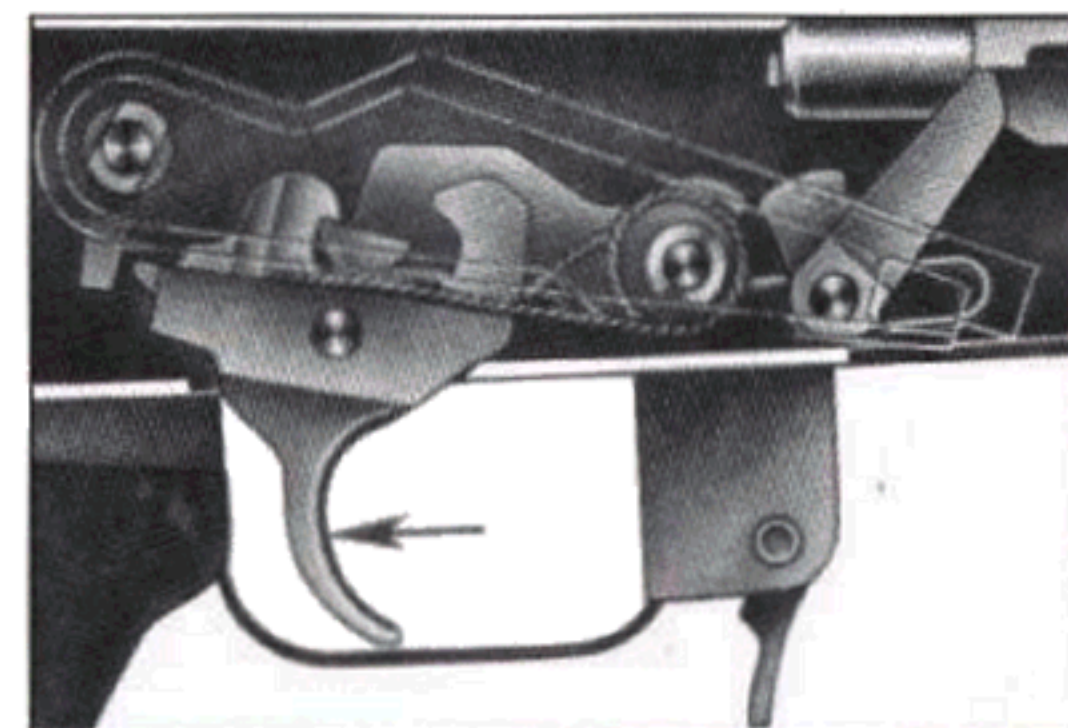

Fig. 4 The mechanism shown during firing. The safety lever is placed on "FIRE," which allows the trigger to be pulled back to release the hammer.

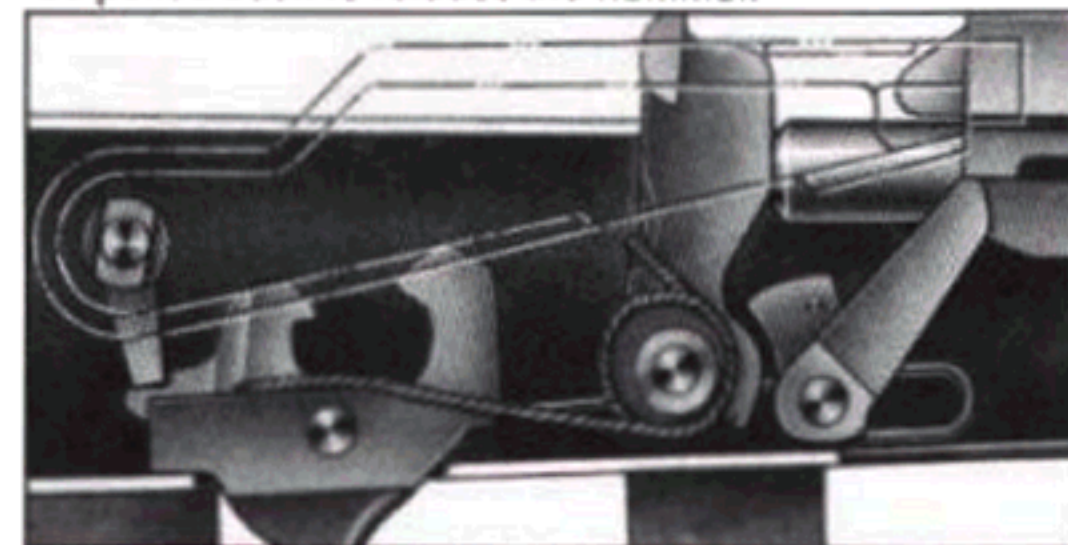

Fig. 5 The mechanism shown with the hammer down and the safety lever placed on "SAFE."

Note: These drawings are taken from Chinese military reference manuals. Unlike your Poly Tech AK-47/S, the mechanism depicted in these illustrations is capable of functioning in a "full-auto" mode.



TECHNICAL DATA:

Caliber: 7.62x39mm

Overall length: 874mm (34.41 in.)

Barrel length: 415mm (16.34 in.)

Rifling: RH twist, 4 grooves,
1 turn in 240mm (9.45 in.)

Method of Actuation: Gas

Sight radius: 378mm (14.88 in.)

Sight type: Protected front post,
adjustable for elevation and windage
Tangent rear, graduated from 100
meters to 800 meters with quick
“D” (300m) setting.

Weight:

(rifle with empty magazine)—4.03 kg (8.87 lbs.)

(rifle with loaded magazine)—4.52 kg (9.94 lbs.)

(empty magazine)—0.33 kg (0.73 lbs.)



STANDARD ACCESSORIES

- 3 30-round box magazines
- 1 Bayonet with scabbard
- 1 Sling
- 1 Oil bottle
- 1 Cleaning rod
- 1 Bore brush
- 1 Patch holder
- 1 Combination tool

OPTIONAL ACCESSORIES

- Quick-loading device
- Sight adjusting tools (windage and elevation)
- Blank firing device
- 5-round, 20-round, 40-round box magazines
- 75-round drum magazine
- Magazine carrying pouch

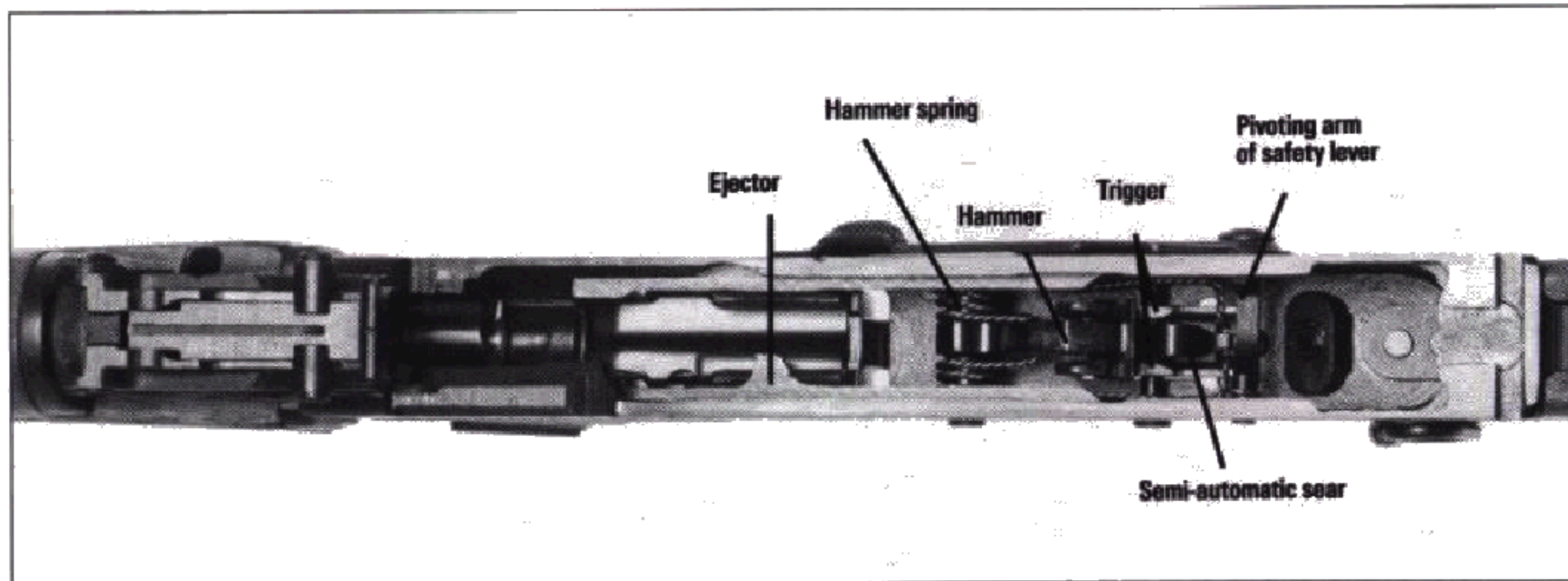

Fig. 6 Top-view of AK-47S receiver.

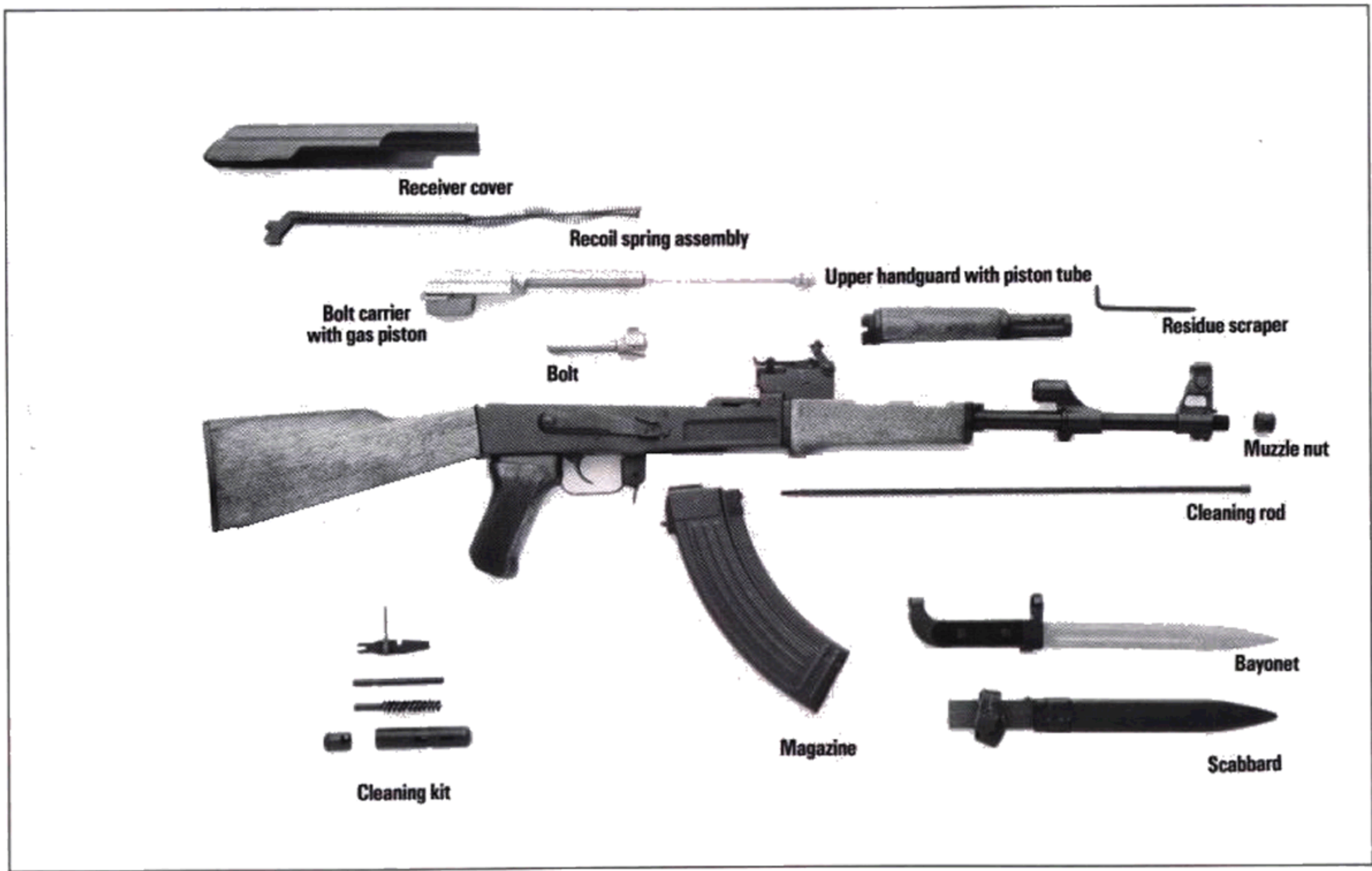



Fig. 7 The AK-47S disassembled.

IMPORTANT PRECAUTIONS FOR SAFE OPERATION AND HANDLING OF YOUR RIFLE

- 1. Understand the operation of the firearm and become familiar with it before attempting to use the firearm.** Begin with the firearm unloaded and familiarize yourself with the operation of its controls.
- 2. Keep the muzzle of the firearm pointed in a safe direction at all times.** Never point the firearm at anything that you do not intend to shoot. Exercise extreme caution when loading or unloading your firearm.
- 3. Keep the firearm unloaded when not in use.** The safest way is to store the ammunition and the firearm separately. Keep firearms out of sight of visitors and children. Remember that it is your responsibility as a gun owner to prevent children and persons unfamiliar with firearms from gaining access to firearms and ammunition.
- 4. Be absolutely certain of your target and the backstop before firing.** Take time to check if you are uncertain of what's behind your target. Never shoot at aerial targets or other targets that do not have a safe backstop. Modern rifle cartridges have lethal ranges of several miles.
- 5. Before loading and firing, inspect the bore to make certain it is unobstructed.** Firing a gun with an obstruction in the bore, even a coat of oil, can cause the barrel to rupture upon firing and cause serious injury to the shooter and others nearby.
- 6. Never rely exclusively on your firearm's mechanical safety.** No guarantee can be made that the firearm will not fire even if the safety is in the "safe" position. Exercise good judgement. Always unload the firearm before negotiating an obstacle.

- 
7. **Don't shoot at a hard surface or at water.** A bullet may ricochet and then fly in unpredictable directions; causing death, injury and damage to property.
 8. **Never handle a firearm without checking to see if it's unloaded.**
 9. **Never transport a loaded firearm.** Firearms should be unloaded before being placed in a vehicle. The firearm should be kept in a carrying case to protect it during transport.
 10. **Always wear proper shooting glasses and hearing protection while shooting.**
 11. **When a cartridge fails to fire,** keep the muzzle pointed in a safe direction and hold the firearm in this manner for 30 seconds. Then, remove the magazine and open the action slowly to retrieve the unfired cartridge. Examine the primer. If the firing pin indent in the primer appears normal, the cartridge should be safely disposed of. If the indent is light or misaligned, the firearm should be returned to the factory-authorized repair center. The cause of the malfunction should be corrected before further use.

MANUFACTURER'S WARNINGS AND DISCLAIMERS

IMPORTANT: READ THIS MANUAL CAREFULLY BEFORE ATTEMPTING TO USE THE FIREARM.

Firearms can be very dangerous if used carelessly. Read this manual and the warnings (printed in red) thoroughly before attempting to use this firearm. If this firearm is improperly handled or used, accidental discharge could result, causing serious injury, death and/or property damage.

WARNING: MAKING MODIFICATIONS TO THIS FIREARM CAN BE VERY DANGEROUS AND SHOULD NOT BE ATTEMPTED.

Do not attempt to modify this firearm or any part of this firearm. Such modifications can be extremely dangerous and will automatically terminate the firearm's limited warranty. Poly Technologies, Inc. ("Poly Tech"), the manufacturer of this firearm, and Keng's Firearms Specialty, Inc. ("KFS"), the importer of this firearm, will not be held responsible for any injury, death or property damage resulting from **any** unauthorized modification of the firearm. In addition, Poly Tech and KFS will not be held responsible for incidental or consequential damages resulting from the addition and/or substitution of any part, component or accessory that is not specifically made for use with this firearm by Poly Technologies, Inc.

Any modifications performed on this firearm after it leaves our control is contrary to our instructions. **Please do not jeopardize your safety and the safety of others by making modifications to this firearm.**

WARNING: USE ONLY HIGH QUALITY FACTORY-LOADED AMMUNITION IN THIS CALIBER.

The Poly Tech AK-47S is chambered for the 7.62x39mm cartridge. The caliber is marked on the left side of the receiver.

Never use ammunition of any other caliber in this firearm. Use only new FACTORY-LOADED ammunition of high quality and in good condition. For optimum results, Poly Tech recommends the use of Chinese military Match ammunition. Never use RELOADED ("remanufactured" or "hand-loaded") ammunition or ammunition that is otherwise faulty, incorrect or non-standard in any way. The manufacturer and the importer of this firearm will not be held responsible for injuries, deaths and damages to property occurring in connection with or as the direct or indirect result of the use of faulty, incorrect or non-standard ammunition in this firearm.

The Poly Tech AK-47S is designed to function with factory-loaded ammunition only. This includes standard Mil-Spec ball (Chinese, Yugoslavian, PMC or Lapua), commercial soft-point and Chinese Mil-Spec blank ammunition (when used with the proper adaptor). All other types of ammunition are defined by Poly Tech and KFS as non-standard. **Never use Tracer, Incendiary, Incendiary-Tracer, Armor-piercing, or any other type(s) of non-standard ammunition in this firearm.** The manufacturer and importer of this firearm will not be held responsible for injuries, deaths and damages to property either occurring in connection with or as the direct or indirect result of the use of non-standard ammunition in this firearm.

NOTICE: UNWARRANTED REPAIRS AND DISASSEMBLY WILL TERMINATE YOUR RIFLE'S LIMITED WARRANTY

Your Poly Tech AK-47S rifle should only be repaired by the factory-authorized repair center as printed on the warranty registration card. Do not have the firearm repaired by anyone else. Any work done by others will automatically terminate your firearm's limited warranty.

NOTICE: THE ADDITION AND/OR SUBSTITUTION OF ANY PART, COMPONENT OR ACCESSORY NOT MANUFACTURED OR APPROVED BY POLY TECHNOLOGIES, INC. OR THE USE OF SUCH PARTS, COMPONENTS AND ACCESSORIES IN CONJUNCTION WITH THIS RIFLE WILL AUTOMATICALLY TERMINATE THE RIFLE'S LIMITED WARRANTY.

THE REMOVAL OF ANY PART OR COMPONENT OF THE RIFLE SHALL ALSO BE CONSTRUED BY THE MANUFACTURER AS MODIFICATION OF THE FIREARM. SUCH ACTION, IF UNDERTAKEN, WILL AUTOMATICALLY TERMINATE THE RIFLE'S LIMITED WARRANTY.



Fig. 8 The safety lever in the "SAFE" position.



Fig. 9 The safety lever in the "FIRE" position.

HANDLING AND OPERATION OF THE AK-47S

OPERATION OF THE SAFETY LEVER

The safety lever of the AK-47S is located on the right side of the receiver. It has two positions: "SAFE" in the upper position as marked with a "S" (see Fig. 8), and "FIRE" in the lower position as marked with a "F" (see Fig. 9).

When placed in the "SAFE" position, the safety lever blocks the trigger, so that it cannot release the hammer. The safety lever also obstructs the operating handle so that it cannot be pulled back far enough to chamber a round with the safety lever on "SAFE."

The manufacturer strongly recommends that the safety lever be kept on "SAFE" at all times when the firearm is not in use. The safety lever also serves as a dust cover by preventing foreign objects from entering the rifle's mechanism.

The safety lever of the AK-47S makes a positive "click" sound whenever the safety lever is fully engaged in either the "SAFE" or the "FIRE" position. The shooter should hear the "click" whenever moving the safety lever from one position to the other. If you do not hear it, check to make sure that the safety lever is not in between the "SAFE" and "FIRE" positions.

Unlike safeties on other rifles, the safety lever of the AK-47S cannot be easily manipulated by right-handed shooters unless the shooter removes his index finger from the trigger guard.

WE STRONGLY URGE ALL SHOOTERS, LEFT AND RIGHT-HANDED, TO KEEP THEIR FINGERS OUTSIDE THE TRIGGER GUARD WHEN OPERATING THE SAFETY LEVER IN ORDER TO AVOID THE POSSIBILITY OF ACCIDENTAL DISCHARGE.

LOADING THE MAGAZINE

1. Load the standard magazine by placing a cartridge between the feed lips of the magazine and pressing it down into the magazine (see Fig. 10). Repeat until the magazine is full.
2. When using the accessory quick-loading tool to load the magazine, refer to Fig. 11.
3. Make sure that the tip of the first cartridge does not protrude beyond the front of the magazine as this will interfere with the insertion of the magazine.
4. The maximum capacity of the standard AK-47S magazine is thirty (30) rounds. Do not exceed this capacity as it may damage the magazine or cause the rifle to malfunction.
5. Optional magazines are available with capacities ranging from 5 to 40 rounds. These magazines are all loaded in the same fashion as the standard magazine.



Fig. 12 Rifle with 5-round box magazine in place.



Fig. 10 Loading the magazine.



Fig. 11 Loading the magazine using the quick-loading tool and ammo on 10-round stripper clips.



Fig. 13 Inserting the magazine.



Fig. 14 Chambering a round in the rifle (Note that the fingers are kept away from the trigger guard).

CHAMBERING A ROUND IN THE RIFLE

IMPORTANT: READ THROUGH THE ENTIRE MANUAL BEFORE LOADING THE RIFLE. PAY SPECIAL ATTENTION TO THE WARNINGS AND PRECAUTIONS CONTAINED THROUGHOUT THIS MANUAL.

Warning: Keep your fingers away from the trigger throughout this sequence.

Important: Do not chamber a round in the rifle unless you are ready to fire the rifle.

1. Place the safety lever in the "SAFE" position.
2. Insert the magazine into the magazine well, canting the magazine forward (see Fig. 13) so that the lug at the front portion of the magazine engages into the recess in the magazine well. Swing the magazine and lock it into place with a rotating motion.
3. With the muzzle pointed in a safe direction, place the safety lever in the "FIRE" position.
4. Pull the operating handle back (see Fig. 14) and release it, allowing it to go forward and chamber a round.

The rifle is now loaded and ready to fire. If you do not intend to fire the rifle, put the safety lever in the "SAFE" position immediately. This will lock the trigger but will still allow the operating handle to be pulled back enough to see if the rifle is loaded.

UNLOADING THE RIFLE

Warning: Keep your fingers away from the trigger throughout this sequence.

1. Place the safety lever in the "SAFE" position.
2. Press the magazine catch and pull out the magazine (see Fig. 15).
3. With the magazine out, place the safety lever in the "FIRE" position and pull the bolt carrier back to eject the unfired round.
4. Always visually inspect the chamber afterwards to verify that the rifle is unloaded. Point the muzzle in a safe direction, squeeze the trigger to let the hammer down. This will prevent unnecessary wear on the hammer spring.
5. Place the safety lever in the "SAFE" position.

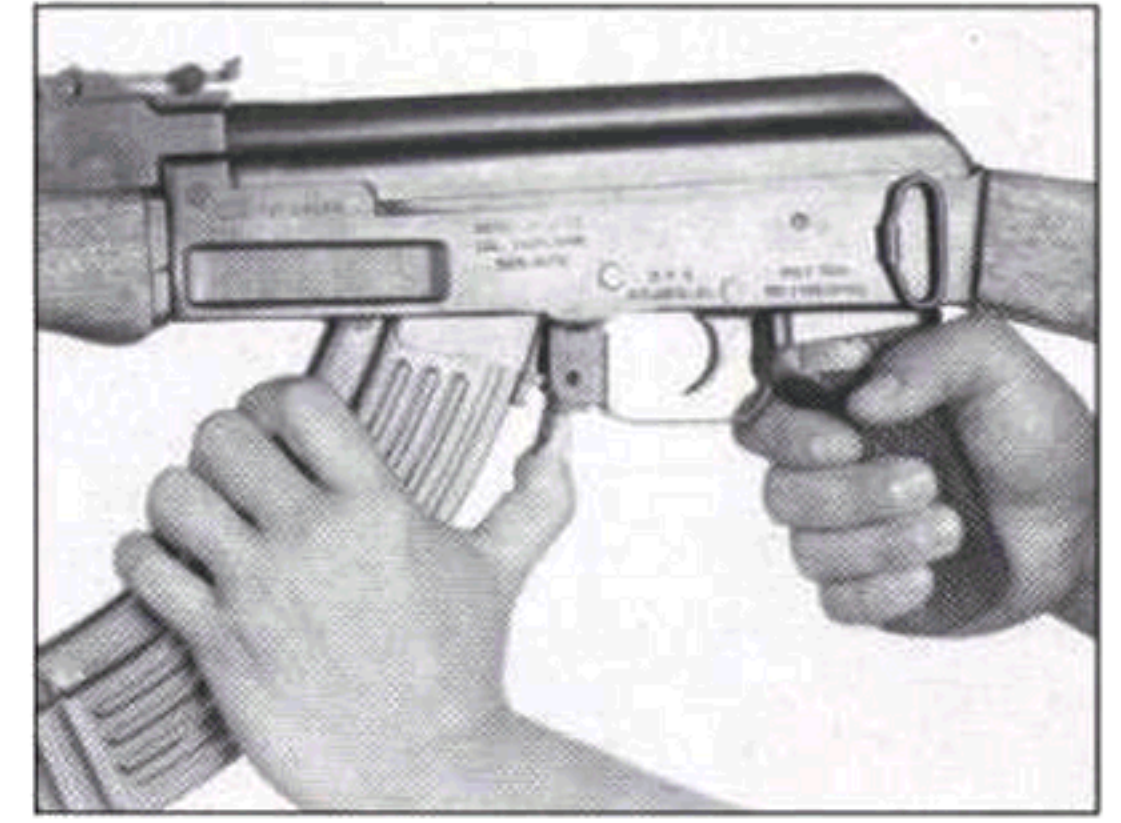

Fig. 15 Removing the magazine from the rifle.

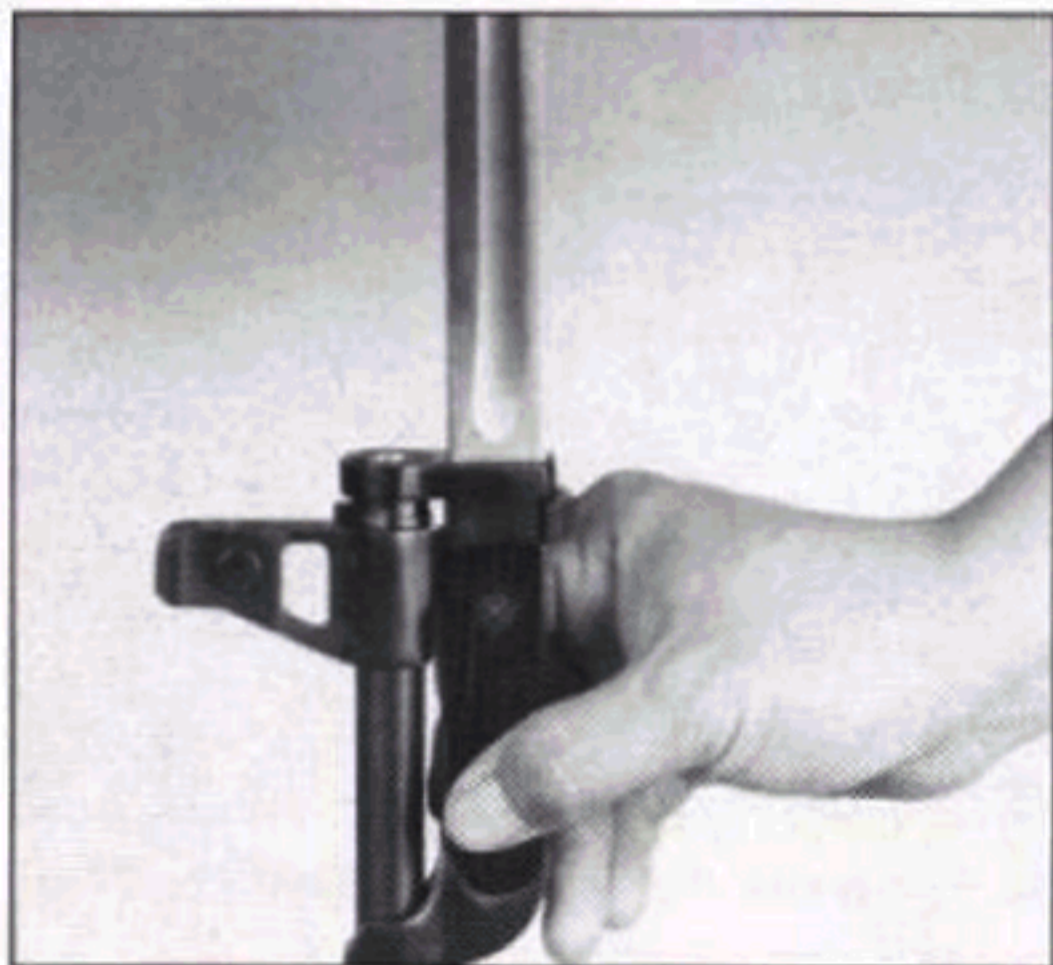

Fig. 16 Mounting the bayonet.

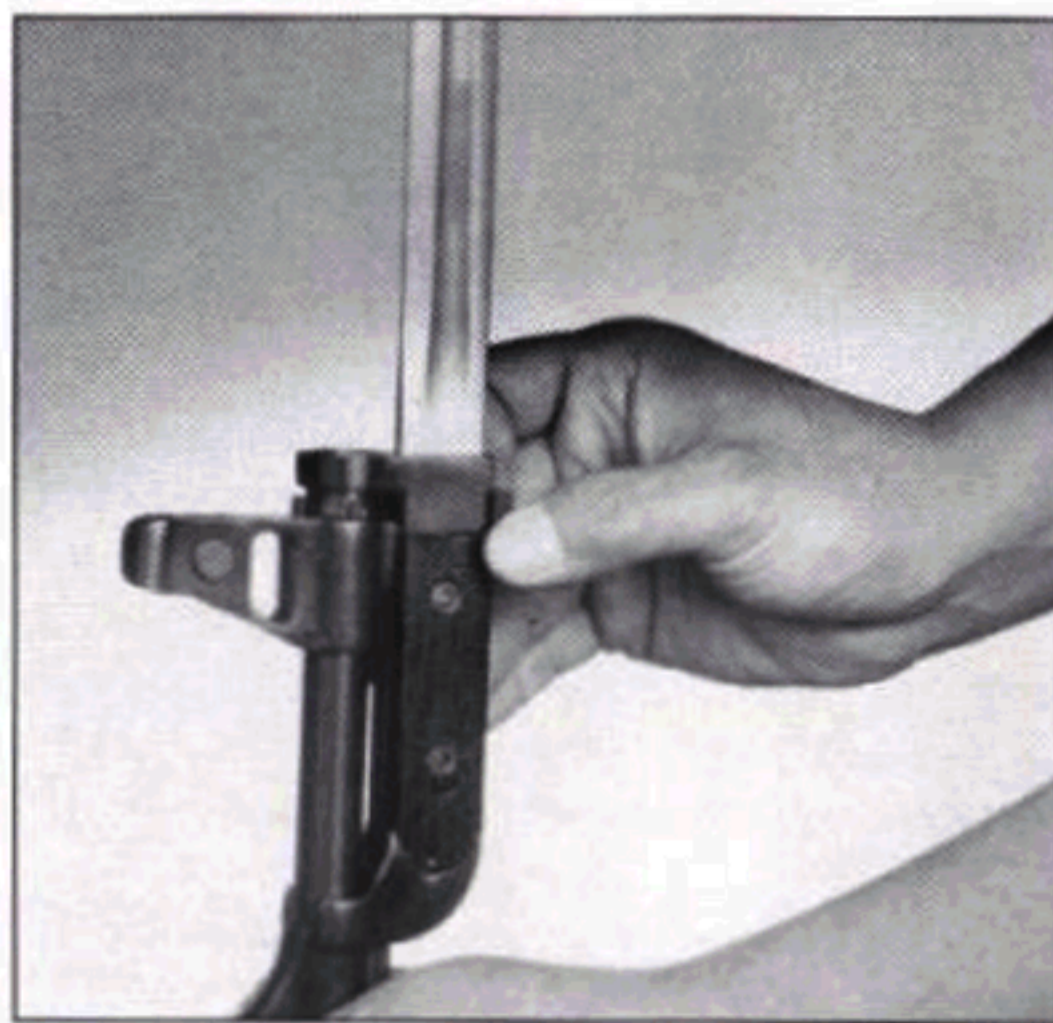

Fig. 17 Removing the bayonet.

MOUNTING THE BAYONET

NOTICE: The bayonet furnished with the rifle is solely for display purposes. The manufacturer and importer of the rifle do not condone and will not be held responsible for its use in any other manner or instance.

1. With the rifle unloaded, hold the rifle upright with its buttstock on the ground.
2. Slide the muzzle ring of the bayonet over the muzzle and the half-ring over the gas block; push the bayonet down firmly (see Fig. 16) until the bayonet catch engages the muzzle nut.

TO REMOVE THE BAYONET

1. Hold the bayonet with one hand and hold the rifle with the other hand.
2. Pull the bayonet catch away from the handle and lift the bayonet off (see Fig. 17). **PLEASE EXERCISE EXTREME CAUTION WHEN REMOVING THE BAYONET.**

INSTALLING THE BLANK FIRING DEVICE

A blank firing device is available as an accessory for the AK-47S. It can be screwed onto the muzzle in the place of the muzzle nut (see Fig. 18). The device should be locked in place by the spring-loaded plunger.

WARNING: Use only original Chinese Mil-Spec blanks in this rifle. Never use home made blanks or any other type of ammunition in the rifle with the blank firing device installed. Accidentally using live ammunition with the blank firing device could result in death or serious injury. For this reason, ALL BLANK FIRING ADAPTORS DEVICES MADE BY POLY TECH ARE PAINTED WITH A HIGH-VISIBILITY ORANGE FINISH.



Fig. 18 Rifle with the blank firing device installed.

ZEROING THE FRONT SIGHT USING THE COMBINATION TOOL

The front sight post can be screwed in or out of its base to adjust for elevation zero. To adjust for elevation:

1. Insert the screwdriver end of the combination tool through the two slots at the center of the accessory tube (as shown in Fig. 19).
2. Fit the front sight wrench over the front sight post (Fig. 21). Turn counterclockwise to raise the sight, clockwise to lower it.

For windage (lateral) adjustment, move the cylindrical front sight post as needed. This can be accomplished using a hammer and proper size punch.



Fig. 19 The combination tool used as front sight wrench.



Fig. 20 The combination tool used as a screwdriver.

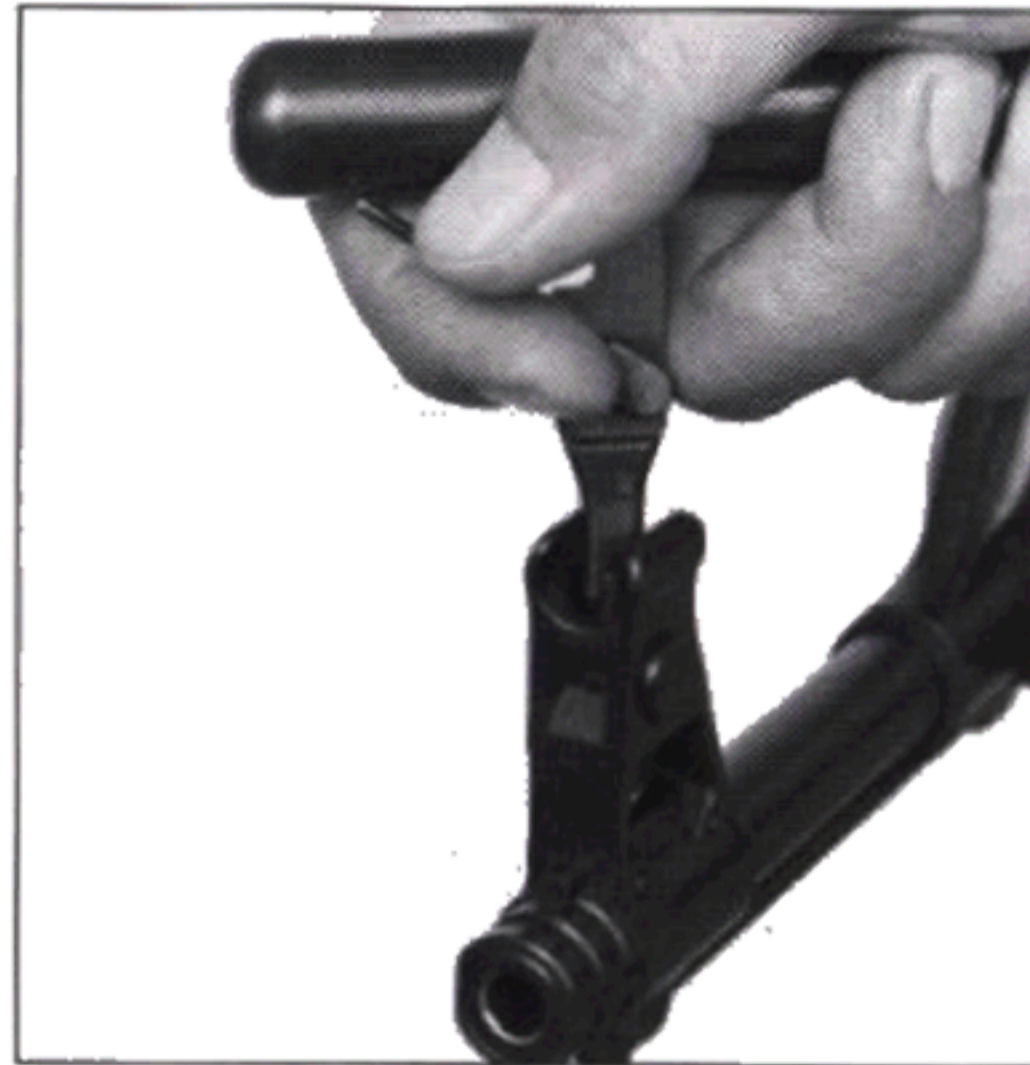

Fig. 21 Using the combination tool to adjust front sight (elevation).

ZEROING THE FRONT SIGHT USING THE OPTIONAL SIGHT ADJUSTMENT TOOLS

For elevation adjustment, position the tool over the front sight post (see Fig. 22). Turn counterclockwise to raise the sight, clockwise to lower it.

For windage adjustment, position the claw-shaped tool over the front sight as shown in Fig. 23.

ATTACHING THE CARRYING SLING

1. Slide the end of the sling with the leather tab attached through the rear sling swivel.
2. Pull the sling through the swivel and slip the leather tab through the buckle.
3. Attach the sling to the front sling swivel by inserting the leather tab through the swivel and secure it with the aluminum button (see Fig. 24).



Fig. 24 The rifle with web sling attached.

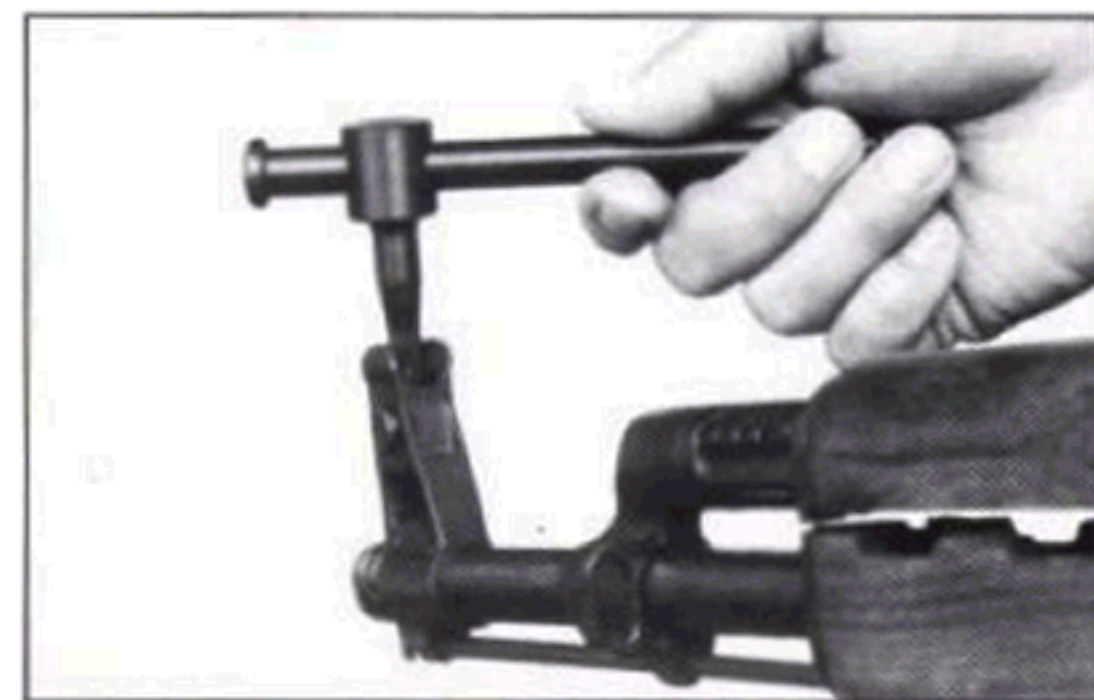

Fig. 22 Adjusting the front sight (elevation) using the optional front sight adjustment tool.

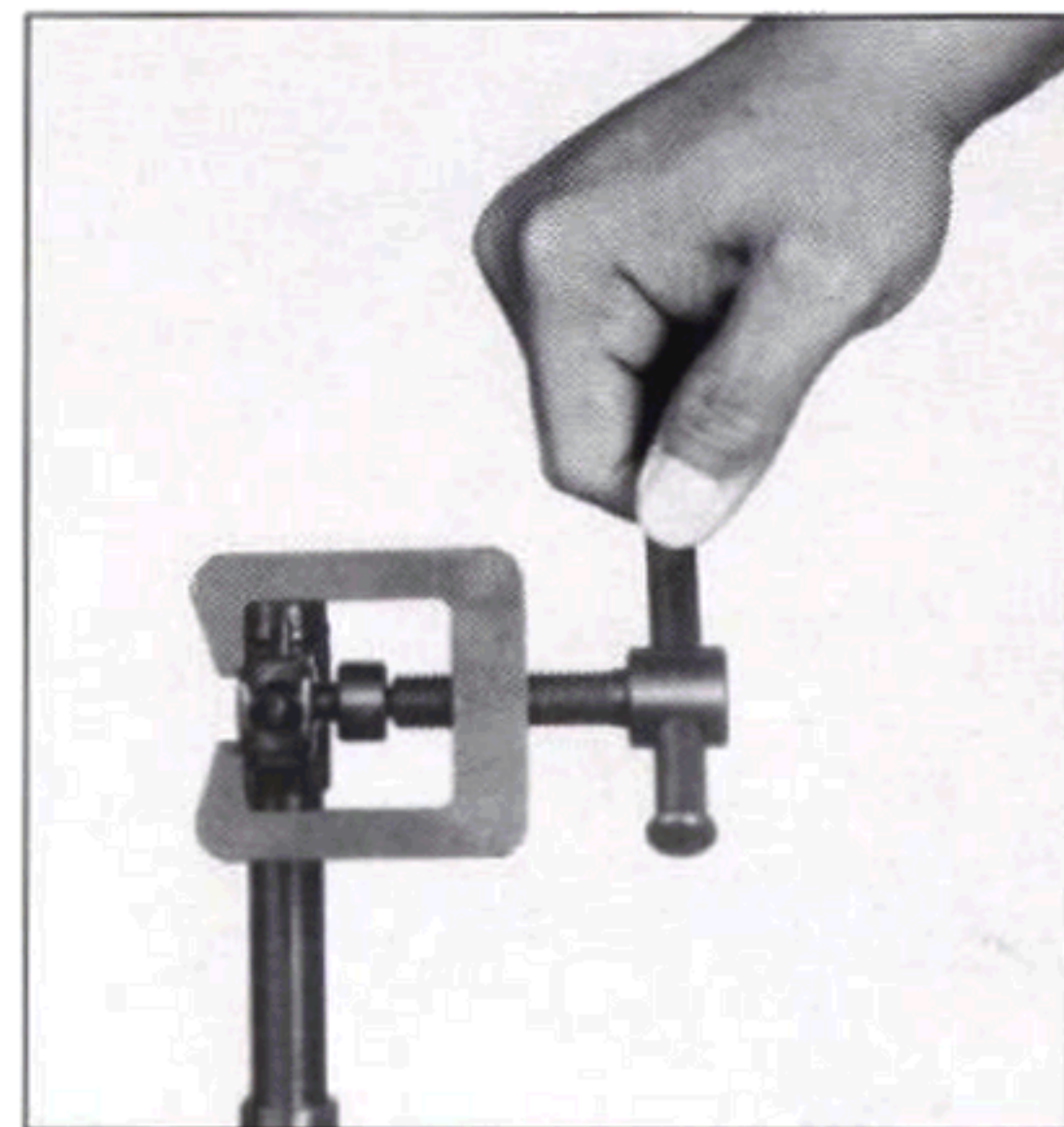

Fig. 23 Adjusting the front sight (windage) using the optional front sight adjustment tool.

PREPARING THE RIFLE FOR DISASSEMBLY

CAUTION: You should never attempt to disassemble the rifle completely. Use the following sequence to disassemble the rifle for cleaning purposes and for maintenance. Further disassembly is strongly discouraged and, if performed, will automatically terminate your firearm's limited warranty.

Before disassembling the rifle:

1. Remove the magazine and place the safety lever in the "FIRE" position. **WARNING: Keep your fingers away from the trigger.**
2. Pull the bolt carrier back and inspect the chamber to make sure that the rifle is unloaded. Release the bolt carrier and leave the hammer in the cocked position.

DISASSEMBLY

To disassemble the rifle for cleaning, use the following procedure. No tools are required other than the accessory kit provided with the rifle.

NOTICE: The manufacturer and the importer of this firearm lets it be known that further disassembly of the firearm, or the removal of any part of the firearm other than what is described in this instruction manual, will constitute a violation of the conditions for the firearm's limited warranty and will automatically terminate the warranty.

Disassembly of those parts of the firearm that are not covered in this instruction manual should only be done by factory-trained gunsmiths. The manufacturer and the importer of this firearm will not be responsible for incidental or consequential damages resulting from unwarranted disassembly and/or incorrect reassembly of this firearm.

1. Push the serrated tip of the recoil spring guide (the portion that protrudes from the receiver cover) into the receiver cover (Fig. 25) and lift off the receiver cover (Fig. 26).
2. Push the recoil spring guide out of its retaining slot and pull the entire assembly out of the bolt carrier (Fig. 27).
3. Pull the operating handle fully to the rear. Lift the bolt carrier slightly upward (see Fig. 28) and remove the entire bolt carrier/gas piston assembly.

continued on next page



Fig. 27 Pulling the recoil spring assembly out of the bolt carrier.



Fig. 25 Push in the serrated tip of the recoil spring guide . . .



Fig. 26 . . . lift the receiver cover off.



Fig. 28 Pulling the bolt carrier/gas piston out of the receiver.

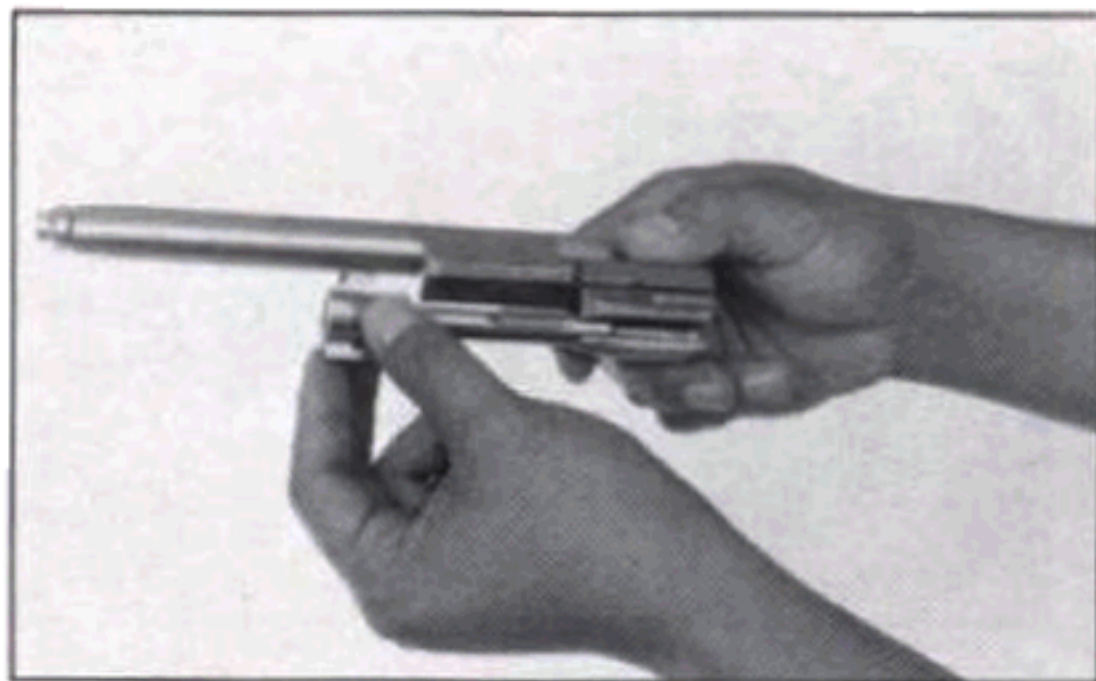

Fig. 29 Separating the bolt from the bolt carrier.

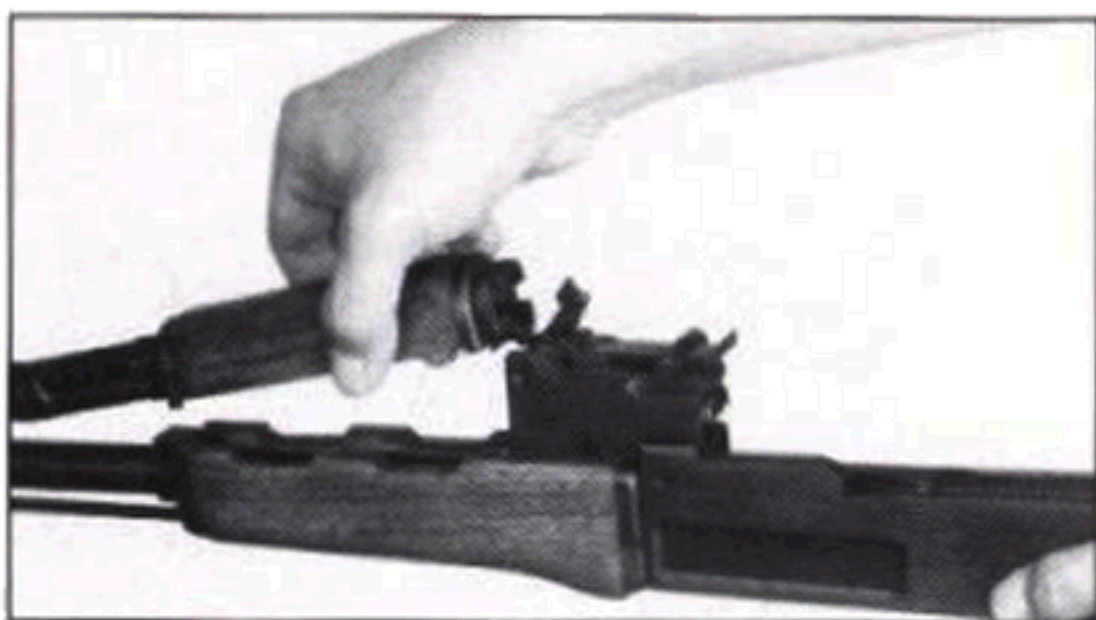

Fig. 30 Lifting the handguard/piston tube off.

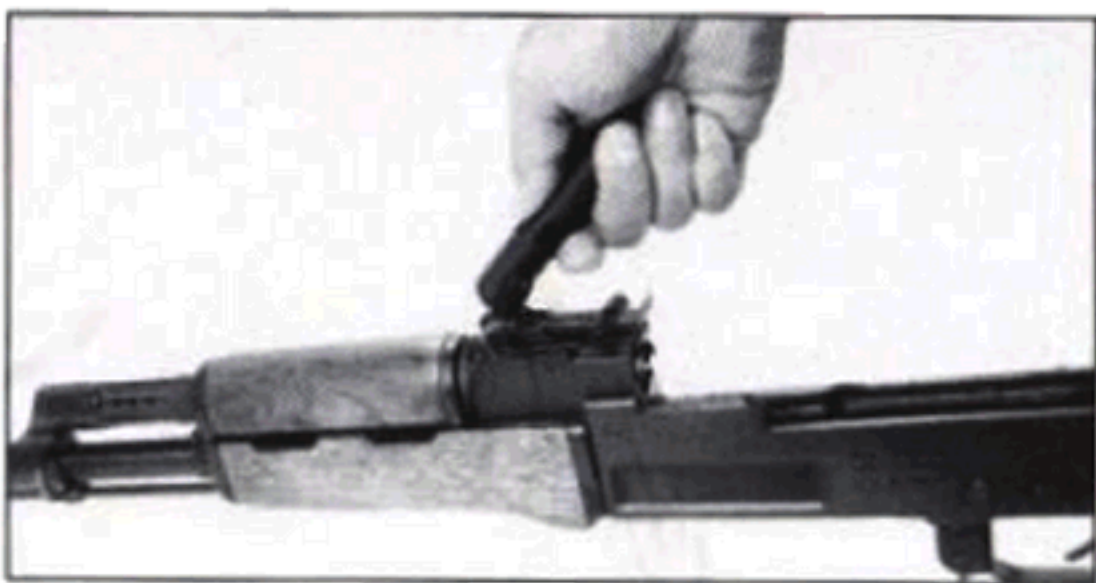

Fig. 31 Using the accessory tube to lift up the piston tube lock lever.

DISASSEMBLY (CONT'D)

4. Separate the bolt from the bolt carrier by turning it $\frac{1}{4}$ th of a turn counterclockwise and removing it from the bolt carrier (see Fig. 29).
5. Raise the piston tube lock lever (located on the right side of the rear sight housing) and rotate it one quarter ($\frac{1}{4}$) of a turn from its locked position. The handguard/piston tube can be lifted off (see Fig. 30).
6. If the lock lever is stiff, use the accessory tube for greater leverage. Use the narrow slot as shown in Fig. 31.
7. Screw off the muzzle nut at the end of the barrel. Use the punch on the combination tool to depress the spring-loaded plunger and turn the muzzle nut **clockwise** (see Fig. 32).

No further disassembly is necessary or recommended.

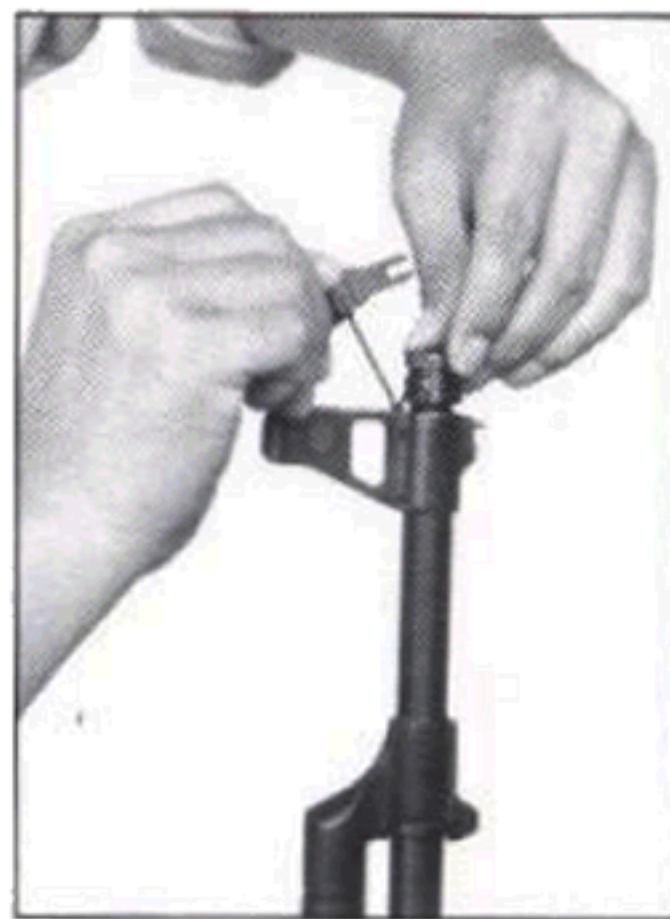

Fig. 32 Screwing the muzzle nut off while depressing the plunger.

REASSEMBLY

Reassembly is essentially the reverse of disassembly. Refer to the photos for the disassembly sequence if you have any questions.

1. Fit the front end of the piston tube onto the opening of the gas block; follow by pressing the upper handguard/piston tube assembly down into position above the barrel. Swing the piston tube lock lever down so that it locks into place.
2. Slide the cylindrical part of the bolt into the hole in the bolt carrier. Turn the bolt clockwise (as viewed from the front) so that the operating lug slides into the lug groove in the bolt carrier. Pull the bolt forward as far as possible in the bolt carrier.
3. Insert the gas piston into the hole underneath the rear sight housing until the bolt carrier is aligned with the cuts at the rear of the receiver. Push the bolt carrier down and then slide it completely forward.
4. Insert the front end of the recoil spring assembly into the hollow upper section of the bolt carrier. Position the recoil spring guide underneath and in front of its retaining slot (see Fig. 33).
5. Position the receiver cover by first aligning the front with the shallow, circular groove behind the rear sight base. Make sure that the rear of the cover is directly on the receiver and hold down the rear end of the cover.
6. Holding the receiver cover firmly, pull the operating handle back until the recoil spring guide snaps up into place, thus locking the receiver cover.
7. Pull the trigger to release the hammer; this will save unnecessary wear on the hammer spring. Place the safety lever in the "SAFE" position.



Fig. 33 The recoil spring guide placed forward and under its slot during reassembly.



Fig. 34 Depress the spring-loaded trapdoor.



Fig. 35 Remove the cleaning kit from buttstock.

USING THE CLEANING TOOLS

Remove the cleaning kit from the spring-loaded trapdoor in the buttstock (see Fig. 34 and Fig. 35). Remove the cleaning rod from under the barrel. Assemble the cleaning tools as follows:

1. Insert the threaded end of the cleaning rod through the accessory tube; first through the larger hole and then the smaller hole diagonally opposite.
2. Slide the cleaning rod through the top of the accessory tube cap. This is so that the cap can be positioned over the muzzle during cleaning to protect the crown from damage.
3. Screw either the bore brush or the patch holder onto the cleaning rod. See Fig. 37 for completely assembled cleaning rod.

Items needed for cleaning the rifle include the cleaning kit, the cleaning rod, cleaning solvent and a light-weight lubricating oil.

Fig. 37 The cleaning rod, accessory tube and accessory tube cap as used during cleaning.



Fig. 36 Cleaning tools provided with the rifle.

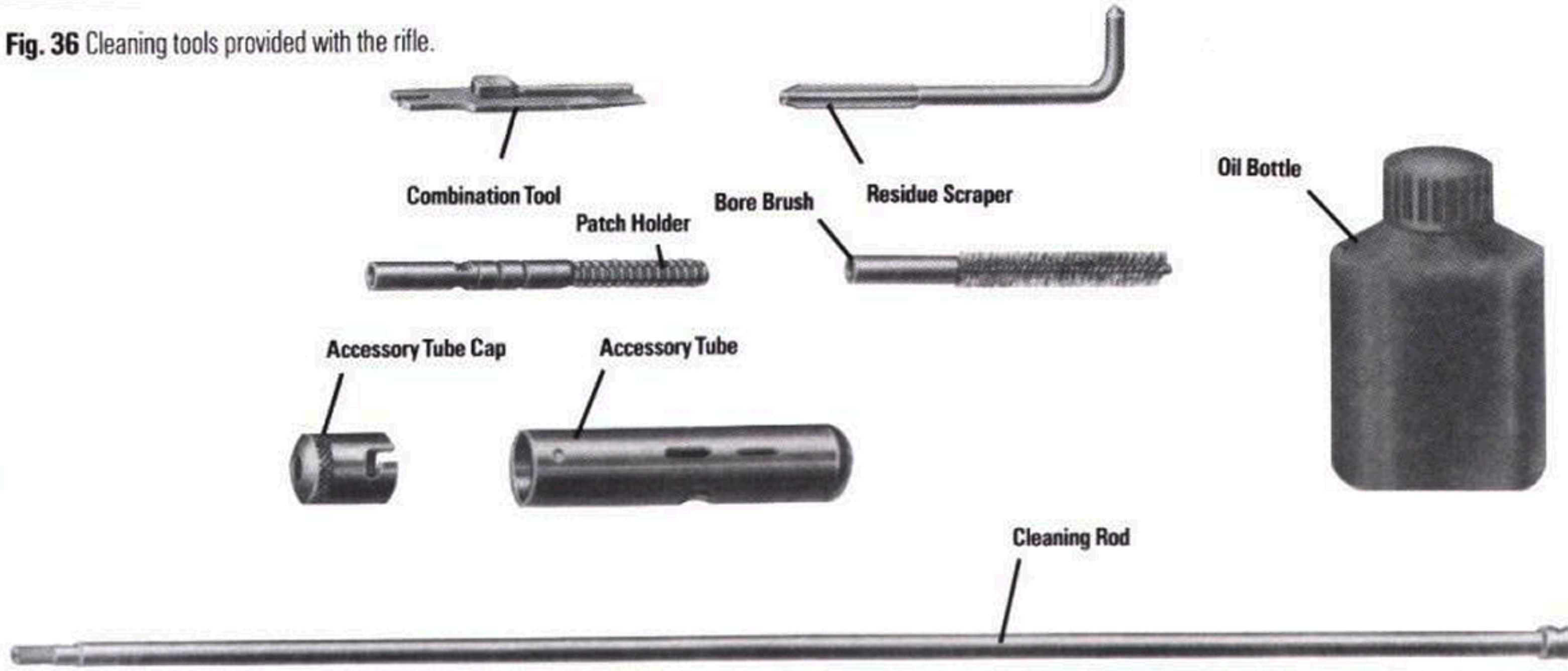



Fig. 38 Insert the squared end of the residue scraper into the gas port.



Fig. 39 Turn the residue scraper until fouling is removed.

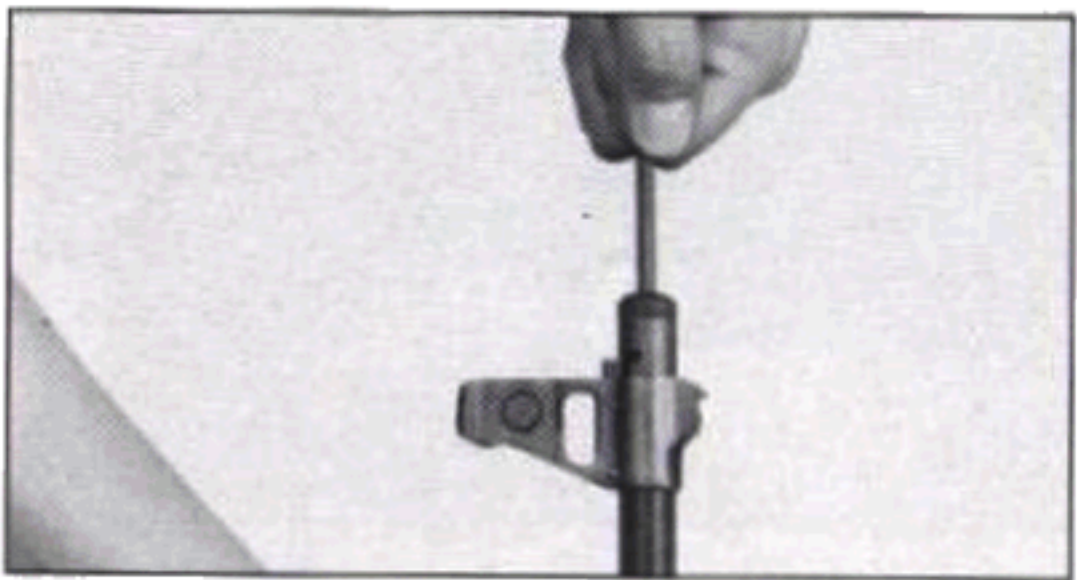

Fig. 40 Cleaning the bore.

CLEANING THE RIFLE

Your rifle should be thoroughly cleaned after each use. The bore, gas system and main components need to be cleaned of all residue. Proper maintenance of your rifle will greatly extend the firearm's service life.

Clean the rifle as follows:

1. Insert the squared end of the L-shaped residue scraper into the gas port (Fig. 38 and Fig. 39) and turn until fouling is removed.
2. Dip the bore brush in solvent. Insert the brush into the barrel as shown in Fig. 40 and push the brush through to the chamber end. Repeat until fouling is removed.
3. Run a dry patch through the bore to remove any solvent left in the bore. The bore should be left dry if the rifle will be fired within a short period. If you do not intend to fire the rifle soon, leave a light film of oil in the bore for protection. However, remember to clean the bore and let dry completely before the rifle is used once more.
4. Clean the gas block, bolt, bolt carrier, gas piston and recoil spring with solvent and wiped dry. Apply a light film of oil on the bolt body, bolt carrier and recoil spring. The gas piston and gas block should be left dry.
5. Wipe off all exposed metal surfaces with an oiled cloth. Special care should be taken to wipe areas where the gun has been exposed to moisture or handling.

Other moving parts in the receiver should be oiled periodically to prevent undue wear. The parts should be lightly oiled, not doused with oil.

MAGAZINE DISASSEMBLY

CAUTION: You should always wear safety goggles when disassembling the magazine.

1. Use a bullet tip to depress the retainer (see Fig. 41) and slip off the magazine floorplate.
2. Pull the magazine spring and follower out of the magazine. The parts of the magazine and the inside of the magazine can now be cleaned.

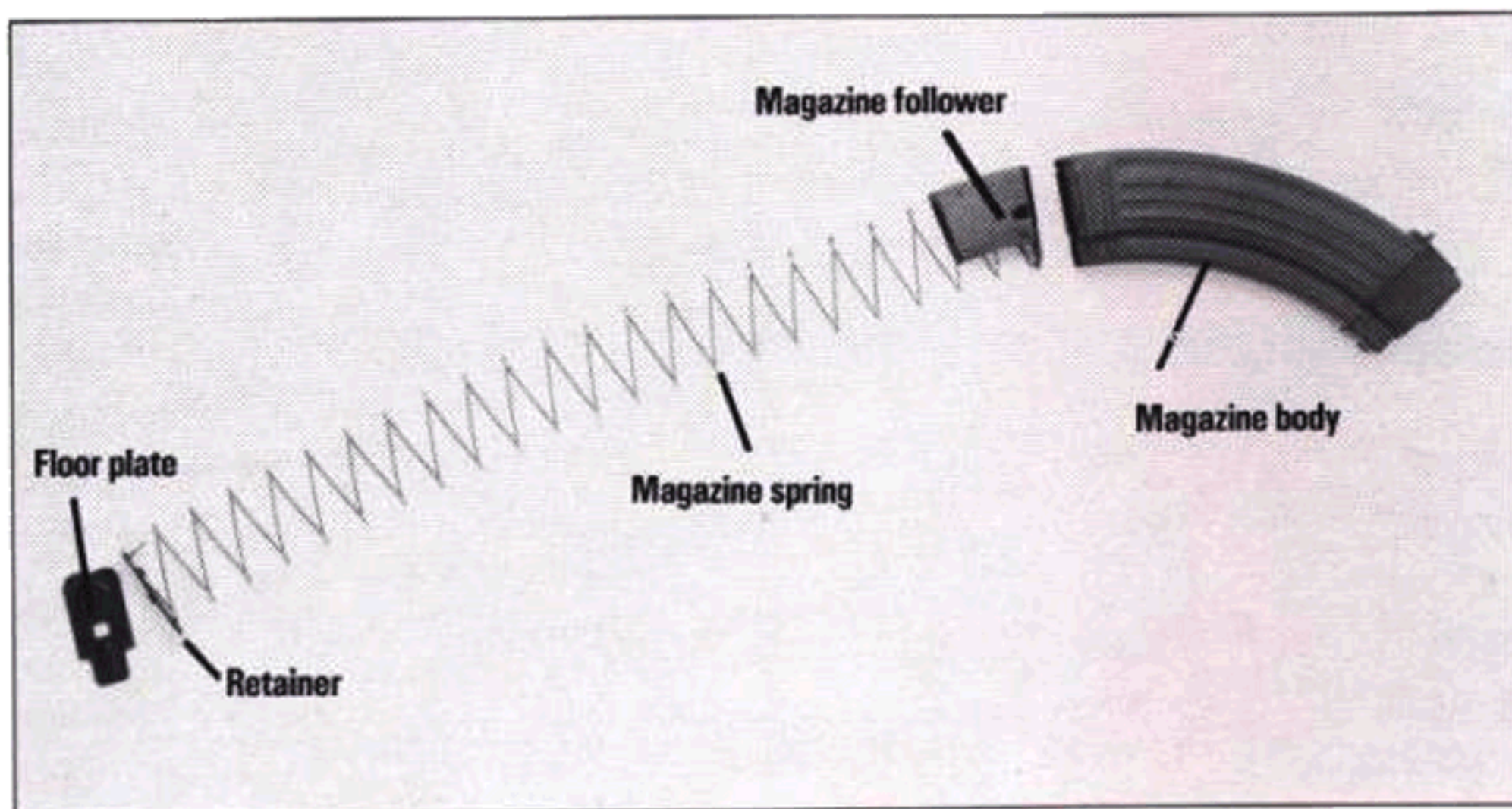

Fig. 42 The magazine disassembled.

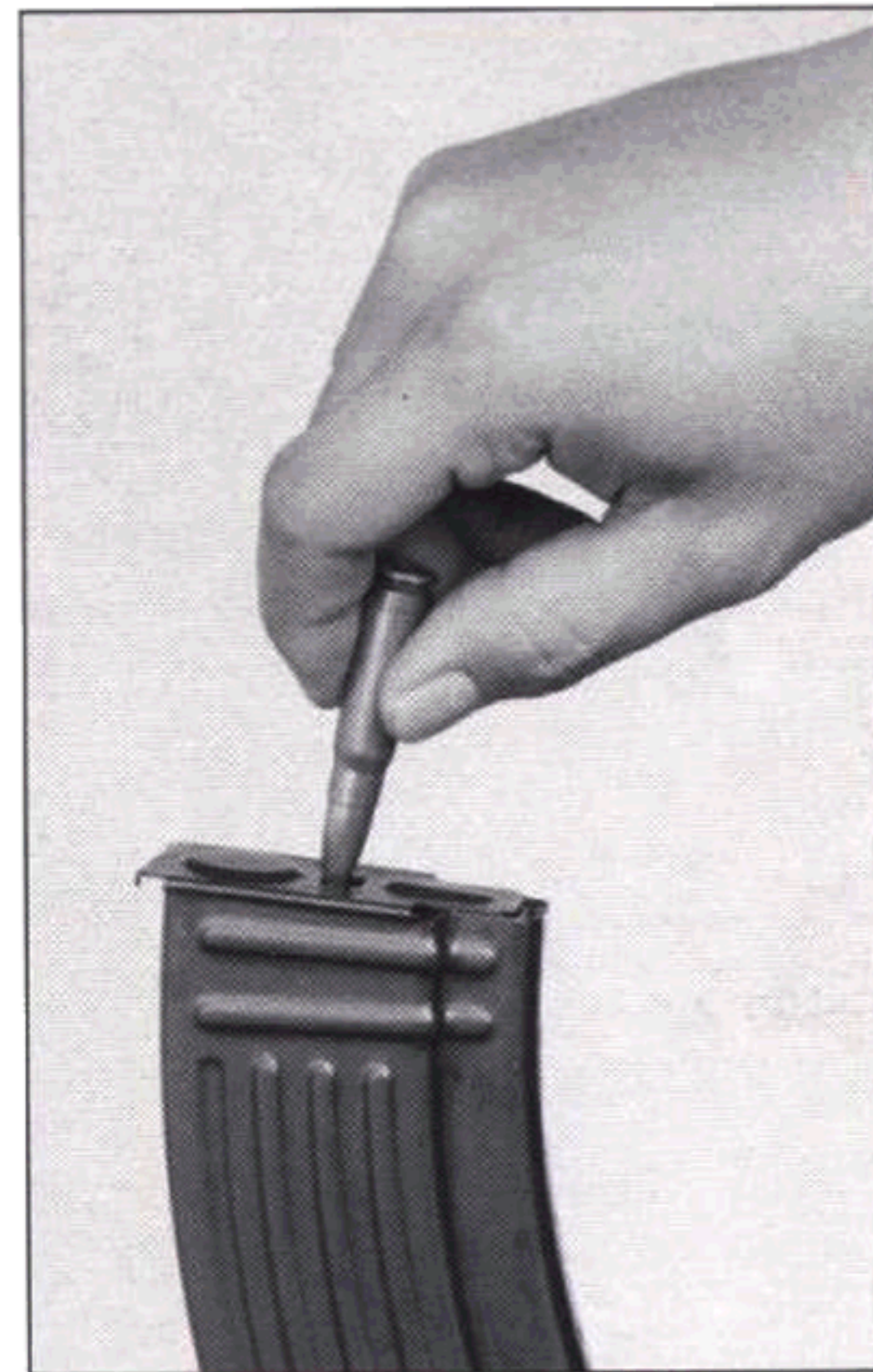

Fig. 41 Use a bullet tip to pry off magazine floorplate. **CAUTION:** wear safety glasses while doing this.

Parts List

Description

Part Number

Safety lever	01-03A
Locking lever, piston tube	01-06
Upper hand guard with piston tube*	01-012
Adjustable base, front sight	01-31
Front sight post	01-32
Rear sight leaf with slide (complete)	02
Rear sight leaf	02-1C
Rear sight slide	02-2
Slide catch	02-3
Spring, slide catch	02-4
Bolt carrier*	03-1A
Piston*	03-2
Bolt body*	03-4
Firing pin (spring-loaded type)*	03-5
Extractor*	03-6
Spring, extractor*	03-7
Retainer, firing pin*	03-9
Pin, extractor*	03-10
Spring, firing pin*	03-11
Guide, recoil spring	04-01 F2
Guide wire, recoil spring	04-2 F2
Recoil spring*	04-3
Retainer, recoil spring	04-4 F2
Stock assembly	05A
Wood screw	05-3

Parts List

Description

Part Number

Spring, accessory housing	05-5
Cover, accessory housing	05-8
Spring, accessory housing cover	05-10
Lower hand guard	06A
Spring, magazine	07-9
Pistol grip	08A
Cover, receiver	00-1A
Hammer*	00-2
Spring, hammer*	00-3
Spring, disconnecter	00-6
Trigger	00-8
Semi-automatic sear*	00-9
Spring, semi-automatic sear*	00-10
Catch, magazine	00-11C
Spring, magazine catch*	00-12
Connecting screw, grip	00-19
Spring, rear sight leaf	00-23
Cleaning rod	00-24
Pin, trigger*	00-25A
Accessory tube	F01-F2
Combination tool	F02 F2
Patch holder	F04
Bore brush	F02
Oil bottle	F06 F2
Residue scraper	F07

*Denotes item is a wearing part

**POLY TECHNOLOGIES, INC.
5/F CITIC BLDG.
BEIJING, CHINA**

THE AUTHORIZED EXCLUSIVE IMPORTER FOR POLY TECH FIREARMS IN THE U.S. IS:

**Keng's Firearms Specialty, Inc.
P.O. Box 1176
Riverdale, GA 30274**

FOR WARRANTY SERVICE, SEND DEFECTIVE FIREARMS TO:

**KFS, Inc.
6030 Hwy. 85-Suite 222
Riverdale, GA 30274
(404) 996-2079**

© 1988, Poly Technologies, Inc.
Printed in U.S.A.